

Z-PC LINE

Digital I/O modules

ZC-16DI-8DO

16CH Digital Input, 8CH Digital Output module / CANopen-ModBUS RTU



NEW
CANopen & ModBUS
all-in-one



Power Supply	10..40 Vdc, 19..28 Vac
Max Consumption	2,5 W
Isolation	1,5 kVac (3 way)
Digital Inputs	16; Nr 8 with totalizer @ 32 bit (max 10 kHz); TPDO < 1 ms
Digital Outputs	8, 32 bit (max 10 kHz); Mosfet, max 500 mA per channel, Vext: 5..30 Vdc; RPDO < 1,25 ms
Supported Protocols	CAN bus standard (2.0A), CANopen (CiA 401 v.2.01), ModBUS RTU
Dip-Switches	Baud rate and ID Node configuration
Operating temperature	-10..+65°C
Dimension (W*H*D)	35 x 100 x 112 mm



➔ For additional information please refer to www.seneca.it

ZC-16DI-8DO

16 CH Digital Input, 8 CH Digital Output module | CANopen-ModBUS RTU



ORDER CODES

Model	ZC-16DI-8DO	16 CH Digital Input, 8 CH Digital Output module / CANopen-ModBUS RTU
Accessories	Z-PC-DINAL1-35 Z-PC-DIN1-35 Z-PC-DIN4-35 PM001601	Terminal block for power / bus + 1 slot 35 mm 1 slot block 35 mm 4 slot block 35 mm Programming serial cable Jack / DB9F
Configuration		EDS File (Electronic Data Sheet) free on www.seneca.it

TECHNICAL FEATURES

GENERAL DATA

Power Supply	10..40 Vdc; 19..28 Vac
Max consumption	1 W
Isolation	1,5 kVac (3 way)
Input Protection	Against ESD up to 4 kV
Rejection	Settable 50 or 60 Hz
Status indicators (LED)	Power Supply, communication, fault
Dimension (WxHxD)	35 x 100 x 112 mm
Enclosure, weight, color	PBT, 140 g, black
Operating temperature	-10..+65°C
Connection	Screw-fit removable for wires up to 3.5 mm IDC10 Back connector for DIN rail frontal Jack RS232 (ModBUS) (COM) connection
Protection degree	IP20
Configuration	DIP switches (baud rate, ID Node) EDS IEC 61131
Supported Protocols	CAN bus standard (2.0A) CANopen (profile CiA 401 v.2.01) ModBUS RTU
Max CANopen Speed	1 Mbps
Norms & Approvals	CE, EN 61000-6-4, EN 64000-6-2, EN 61010-1 CAN 2.0A CiA 401 v.2.01 IEC EN 61131-2

INPUT DATA

Channels	16 (with shared negative pole, selfpowered at 16 Vdc)
Type	EN 61131-2 type 2, synq (pnp); Vmax=30 V
Totalizers	Nr 8 @ 32 bit, freq. max 10 kHz Settable increment, reset, preset, overflow indication
TPDO	< 1 ms

OUTPUT DATA

Channels	8 Mosfet (open source) with shared negative pole
Imax	0.5 A (from terminals); 25 mA (from connectors)
RPDO	< 1,25 ms

CANOPEN FEATURES

NMT	Slave
Error control	Node guarding
Node ID	Software, DIP-switches
Nr PDO	RX 5
PDO Modes	Event Triggered, Sync (cyclic), Sync (acyclic)
PDO linking	Yes
PDO mapping	Variable
Nr SDO Server	1
Emergency Messages	Yes
Application layer	CiA 301 v. 4.02
Profile	CiA 401 v. 2.01

ELECTRICAL CONNECTIONS

Module insertion on DIN guide 46277

IDC10 back connectors

Backplane bus Z-PC DIN

CANbus Connection Norms

Baud rate	Lunghezza bus	Lunghezza derivazione
20 kbps	1000 m	150 m
50 kbps	1000 m	60 m
125 kbps	500 m	5 m
250 kbps	250 m	5 m
500 kbps	100 m	5 m
800 kbps	50 m	3 m
1000 kbps	25 m	0.3 m

Digital Inputs

Fast counters (10 KHz)

Generic Inputs

Digital Outputs

Connection from terminals

Connection from connectors

Connessione seriale RS232 - DB9F / Jack stereo



Contents:

- General Specifications
- Technical Specifications
- Installation Rules
- Electrical connections
- DIP-switches settings
- Programming
- Significant Components Position
- Leds Signallings
- Factory Settings



SENECA s.r.l.
Via Germania, 34 - 35127 - Z.I. CAMIN - PADOVA - ITALY
Tel. +39.049.8705355 - 8705359 - Fax +39.049.8706287
For manuals, EDS files and configuration software, see www.seneca.it

This document is property of SENECA s.r.l. Duplication and reproduction are forbidden, if not authorized. Contents of the present documentation refers to products and technologies described in it. All technical data contained in the document may be modified without prior notice. Content of this documentation is subject to periodical revision.

POWER SUPPLY	
Voltage	10 - 40 V _{DC} or 19 - 28 V _{AC}
Consumption	Typical: 1.5 W, Max: 2.5 W
ENVIRONMENTAL CONDITIONS	
Temperature	-10 - + 65°C
Humidity	30 - 90% at 40°C non condensing
Altitude	up 2000 m a.s.l.
Storage Temperature	-20 - +85°C
Protection	IP20

CONNECTIONS	
Removable Terminals	4-way screw terminals (3.5 mm pitch): inputs/outputs.
Rear IDC10 Connector	CAN/MODBUS Interface and power supply (for DIN rail).
IDC10 Connector on the rear	Digital Outputs (alternatively to terminals).
Stereophonic front jack	3.5 mm. RS232 (COM).

DIMENSIONS / BOX	
Dimensions	L: 100 mm, H: 112 mm, W: 35 mm
Box	PBT, black

ISOLATIONS / STANDARDS

Isolation Diagram	Standards
3-Point 1500 V _{AC} Isolation	<p>The module complies with the following standards:</p> <p>EN61000-6-4/2002-10 (electromagnetic emission, industrial environment).</p> <p>EN61000-6-2/2006-10 (electromagnetic immunity, industrial environment).</p> <p>EN61010-1/2001 (safety).</p> <p>All circuits must be isolated from the other circuits under dangerous voltage with double isolation. The power supply transformer must comply with EN60742: "Isolated transformers and safety transformers".</p>

Installation Rules

The module is designed to be installed in vertical position on a DIN 46277 rail. In order to ensure optimum performance and the longest working life, the module(s) must be supplied adequate ventilation and no raceways or other objects that obstruct the ventilation slots. Never install modules above sources of heat; we recommend installation in the lower part of the control panel.

Inserting on the DIN rail

- 1) Insert the rear IDC10 connector on a DIN rail free slot (the inserting is univocal since the connectors are polarized).
- 2) Tighten the four locks placed at the sides of the rear IDC10 connector to fix the module.

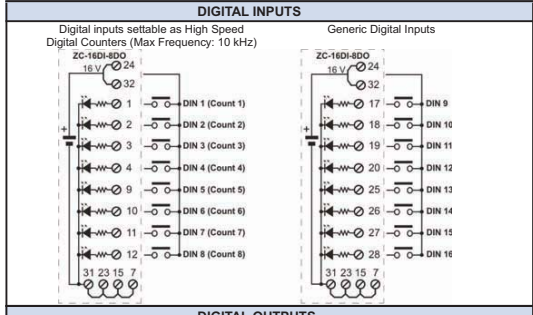
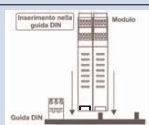

DIGITAL OUTPUTS

The total current entering on power supply terminal must be limited to 1 A with a quick-break fuse or equivalent protection.

Connection suggested to supply 24 V relays. The total current entering on power supply terminal must be limited to 0.2 A with quick-break fuse or equivalent protection.

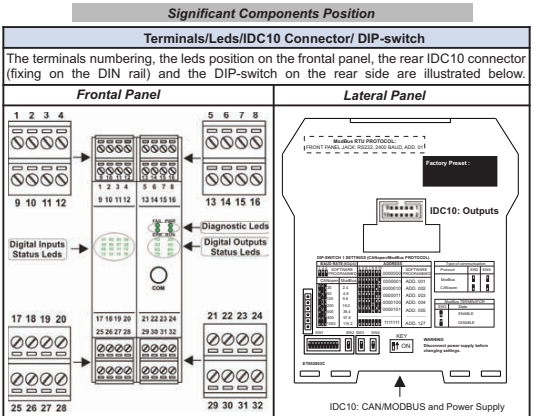
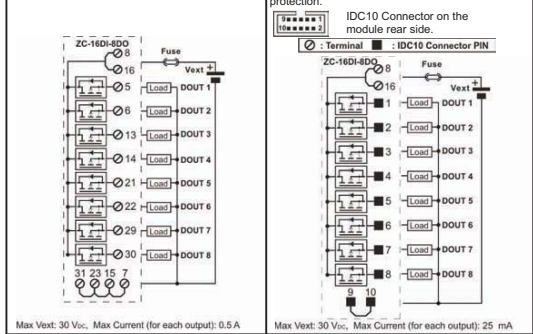

LEDs Signallings

LED ERR E RUN: CANOPEN / MODBUS COMMUNICATION STATE

The meaning of leds ERR and RUN is described below; refer to the User Manual for details about the possible state and the flashing modes of the two leds.

LED ERR (Red)	STATE	LED (Red) ERR (CANOPEN) Meaning
OFF	No error	The Device is in working condition.
Single flash	Warning limit reached	At least one of the error counters of the CAN controller has reached or exceeded the warning level (too many error frames).
Double flash	Error Event	A guard event (NMT-Slave or NMT-master).
Triple flash	Sync Error	The SYNC message has not been received within the communication cycle period time out.
ON	Bus off	The CAN controller is bus off.

LED ERR (Red)	LED (Red) Rx (MODBUS) Meaning
ON	The device is receiving.

General Specifications

- Sixteen 16 V_{DC} self-powered digital inputs with shared negative pole.
- Eight inputs settable as 32-bit counters with 10 kHz maximum frequency.
- Eight Mosfet Digital Outputs with shared negative pole, 5-30 V_{DC} collectively supplied.
- Digital outputs available both by terminals and IDC10 connector to facilitate the connection to external relays.
- Can Interface with CANopen protocol up to 1 Mbps speed or MODBUS RS485 Interface up to 115 Kbit/s speed.
- CANopen/MODBUS Baud rate and Node ID configurability by DIP-switches or software.
- RS232 Serial Communication with MODBUS-RTU protocol.
- Facilitated power supply and CANopen/MODBUS bus wiring by means of the bus housed in the DIN rail.
- 1500 V_{AC} Isolation among input/output, power supply and CAN/MODBUS interface circuits.
- Counters increment individually configurable on the rising or falling edges of the corresponding digital input.
- Overflow indication available for each counter.
- Preset value configurable for each counter.
- Reset and preset commands individually executable on each counter.
- Overtemperature and short-circuit to ground of digital outputs continuous monitoring and consequent fault condition signalling.
- Outputs value in case of no communication or fault condition: programmable value or last set value.
- Leds Signallings: Power Supply, Digital Inputs/Outputs State, CAN/MODBUS Communication, MODBUS-RTU Communication, Outputs fault.

Electrical Connections

POWER SUPPLY AND CAN/MODBUS INTERFACE

Power Supply and CAN/MODBUS interface are available by using the bus for the Seneca DIN rail, by the rear IDC10 connector or by Z-PC-DINAL-1-35 accessory.

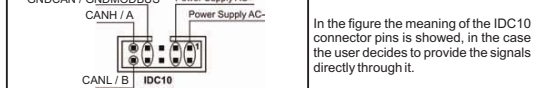

In the figure the meaning of the IDC10 connector pins is showed, in the case the user decides to provide the signals directly through it.

Z-PC-DINAL-1-35 Accessory Use

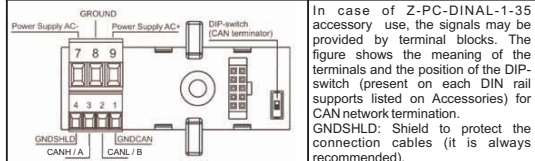

In case of Z-PC-DINAL-1-35 accessory use, the signals may be provided by terminal blocks. The figure shows the meaning of the terminals and the position of the DIP-switch (present on each DIN rail supports listed on Accessories) for CAN network termination.

CAN bus Connection Rules

- 1) Install the modules on the DIN rail (max 120).
- 2) Connect the remote modules using cables of proper length. On the table the following data about the cables length are provided:
 - Bus Length: CAN network maximum length as a function of the Baud rate. It is the length of the cables which connect the two bus terminators modules (see Scheme 1).
 - Drop Length: maximum length of a drop line (see Scheme 1) as a function of the Baud Rate.

Baud rate	Bus Length	Drop Length
20 kbps	2500 m	150 m
50 kbps	1000 m	60 m
125 kbps	500 m	5 m
250 kbps	250 m	5 m
500 kbps	100 m	5 m
800 kbps	50 m	3 m
1000 kbps	25 m	0,3 m

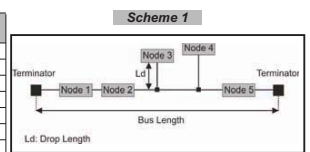

For the best performances, the use of special shielded cables is recommended (BELDEN 9841 cable for example).

3) Terminate the two ends of the CANbus network by setting to ON the DIP-switch present on the DIN rail connection supports (see Accessories) where the two ends are inserted.

RS232 SERIAL PORT

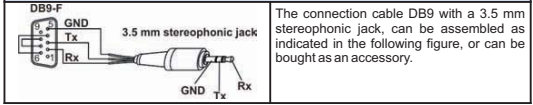

DIP-switches Settings

The DIP-switches position defines the module CAN/MODBUS communication parameters: Address and Baud Rate. In the following figure the Baud Rate and Address values are listed as a function of the DIP-switches position:

BAUD RATE (kbps)	ADDRESS
SOFTWARE PROGRAMMED	SOFTWARE PROGRAMMED
20	00000001
50	00000010
125	00000011
250	00000100
500	00001001
800
1000	11111111

Type of communication	SW2	SW4
Protocol	<input type="checkbox"/>	<input type="checkbox"/>
ModBus	<input type="checkbox"/>	<input type="checkbox"/>
CANopen	<input type="checkbox"/>	<input type="checkbox"/>

ModBUS TERMINATOR	SW3	State
ENABLE	<input type="checkbox"/>	ENABLE
DISABLE	<input type="checkbox"/>	DISABLE

We underline that on all the DIN rail supports a DIP-switch is present and if it is set to ON position the CAN network termination is inserted.

Programming

PROGRAMMING THROUGH CAN/MODBUS INTERFACE

The module may be programmed/configured through the CAN/MODBUS interface; refer to the User Manual for details about the communication.

Factory Parameters

With all the DIP-switches in OFF position (values from memory), the module is originally programmed as follows:
MODBUS, Baud Rate: 38400, Bit: 8, Parity: None, Stop bit: 1, Address: 1
To switching ON SW2 and SW4 : CANOPEN, Baud Rate: 20 kbps, Address: 127.

PROGRAMMING THROUGH RS232 (FRONTAL JACK)

The module may be programmed/configured through the RS232 interface by using MODBUS-RTU protocol; refer to the User Manual for details about the communication. The connection parameters are the following:
Address: 1, Baud Rate: 2400 Baud, Parity: none, Stop bit: 1.

LED RUN (Green)

LED RUN (Green)	STATE	LED (Green) RUN (CANOPEN) Meaning
Single flash	Stop	The Device is in STOPPED state.
Blinking	Pre-operational	The Device is in the PRE-OPERATIONAL state.
Accesso	Operational	The Device is in the OPERATIONAL state.

LED RUN (Green)	LED (Green) Tx (MODBUS) Meaning
ON	The device is transmitting.

LEDS FAIL AND PWR: GENERAL SYSTEM DIAGNOSTICS

LED PWR (Green)	Meaning	LED FAIL (Yellow)	Meaning
ON	Power Supply Presence	ON / Blinking	- Data reception on the RS232 port (COM). - At least an output in Fault

DIGITAL INPUTS / OUTPUTS STATE LEDS

LED 10..80 (Green)	Meaning
ON	The correspondent digital output (10..80) ON

LED 01..16 (Green)	Meaning
ON	-01..08: If counters are enabled: the correspondent counter is ON. -Otherwise it signals the state of the correspondent generic digital input. -09..16: The correspondent generic digital input is ON.

FACTORY SETTINGS



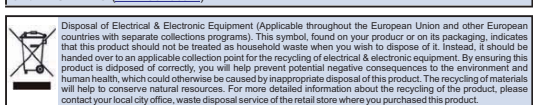

- All DIP-switch OFF:
- MODBUS Protocol / - Communication parameters: 38400 8,N,1 Addr. 1
 - Filter active on the 16 Digital inputs / - Filter value = 100Hz
 - In case of fail, outputs go low.
 - Modbus communication monitoring, not active.

All dip switch OFF except SW2 (ON) and SW4 (ON):
 - CANOPEN Protocol / - Communication parameters: 20K Addr. 127
 - Filter active on the 16 Digital inputs / - Filter value = 100Hz
 - In case of fail, outputs go low.

Variations of standard parameters are possible by using configuration softwares Z-NET and EASY-Z-PC (www.seneca.it).





 	<p>ZC-16DI8DO</p> <p>CANopen/Modbus I/O Module</p> <p>16 Digital Input 8 Digital Output Or 8 Counters (32 bit) 8 Digital Input 8 Digital Output</p>	
<p>User Manual</p>		
	<p>Contents:</p> <ul style="list-style-type: none"> CANopen Features CANopen PDOs CANopen PDO Transmission Type CANopen Emergency Message CANopen Functional Diagram CANopen Object Dictionary Modbus Features Modbus Register Modbus Command 	

CANopen FEATURES

TECHNICAL DATA	
BAUD RATE	20, 50, 125, 250, 500, 800, 1000 Kbits/s
COUNTERS NR/TYPER	8 (32 bit) from input 1..8
MAX FREQUENCY FOR COUNTERS	10 kHz
TYPICAL ON/OFF DELAY	1 ms (filter disabled) for inputs 1.25 ms for outputs
CANopen TECHNICAL DATA	
NMT	SLAVE
ERROR CONTROL	NODE GUARDING
NODE ID	HW SWITCH OR SOFTWARE
NUMBER OF PDO	5 TX, 1 RX
PDO MODES	Event Triggered, Sync (cyclic), Sync (acyclic)
PDO MAPPING	VARIABLE
PDO LINKING	SUPPORTED
NUMBER OF SDO	1 SERVER
ERROR MESSAGE	YES
SUPPORTED APPLICATION	CiA 301 v4.02
LAYER	CiA 401 v2.01

CANopen TPDOs TRANSMISSION TYPE SUPPORTED

OBJECT VALUE 0x180x sub 2	TRANSMISSION TYPE
0	Synchronous - acyclic
From 1 to 240	Synchronous - cyclic
255	Asynchronous

CANopen PDOs MAPPING

OBJECTS FOR DEFAULT MAPPING				
PDO NR	COB-ID	MAPPED OBJECTS	INDEX	SUBINDEX
RPDO1	0x200 + NodeId	Digital Input [1..8]	0x6200	1
TDO1	0x40000180 + NodeId	Digital Input [1..8]	0x6000	1
		Digital Input [9..16]	0x6000	2
		Digital Input [17..24]	0x6000	3
		Overflow counter [1..8]	0x6000	4
TPDO 5	0x40000280 + NodeId	Counter 1 value	0x2210	1
		Counter 2 value	0x2210	2
TPDO 6	0x40000380 + NodeId	Counter 3 value	0x2210	3
		Counter 4 value	0x2210	4
TPDO 7	0x40000480 + NodeId	Counter 5 value	0x2210	5
		Counter 6 value	0x2210	6
TPDO 8	0x40000300 + NodeId	Counter 7 value	0x2210	7
		Counter 8 value	0x2210	8

Note that TPDO COB-ID must starts with 0x4



CANopen EMERGENCY MESSAGE

The Emergency message is composed by:
 2 bytes of EEC (Emergency error code)
 1 bytes of ER (Error Register)
 4 bytes MEF (Manufacturer Error Filled Objects (0x1200))

EMERGENCY MESSAGE						
BYTE0	BYTE1	BYTE2	BYTE3	BYTE4	BYTE5	BYTE6
EER		ER	MEF			

EEC	
CODE	DESCRIPTION
0x0000	No Error
0x1000	Generic error
0x4201	CPU Temperature over T_HIGH_HIGH
0x4202	CPU Temperature over T_HIGH
0x4203	CPU Temperature under T_LOW
0x8110	Communication Can Overrun
0x8120	Error Passive
0x8130	Life Guard Error
0x8140	Recovered From Bus Off
0xFF20	CPU Error
0xFF30	Vext For outputs not found / SPI Communication Error
0xFF50	Output Fail

ER							
BIT7	BIT6	BIT5	BIT4	BIT3	BIT2	BIT1	BIT0
Generic	0	0	Temperature	Communication	0	0	Manufacture

Where if the bit is 0 means no error

CANopen MANUFACTURER SPECIFIC PROFILE

If Hardware switches are in “from memory” mode the node address is selectable by **Object 0x2001**.

NODE ADDRESS (OBJECT 0X2001:)	
OBJECT VALUE	DESCRIPTION
0....127	Node Address

If Hardware switches are in “from memory” mode baud rate is selectable by **Object 0x2002**.

BAUDRATE (OBJECT 0X2002)	
OBJECT VALUE	DESCRIPTION
1	20 Kbit/s
2	50 Kbit/s
3	125 Kbit/s
4	250 Kbit/s
5	500 Kbit/s
6	800 Kbit/s
7	1 Mbit/s

Object 0x2030 can be used for monitoring the CPU temperature

CPU TEMPERATURE (OBJECT 0X2030)	
SUBINDEX	DESCRIPTION
1	Actual Temperature [°C/10]
2	Temperature for HOT STOP ERROR [°C/10] 95.0°
3	Temperature for HOT ERROR [°C/10] 90.0°
4	Temperature for COLD ERROR [°C/10] -25.0°

The HOT STOP Temperature sends in pre-operational the station.

The HOT ERROR and the COLD ERROR Temperature sends the Emergency Object.

The Object is Read Only

Object 0X2051 is used to send commands to the station module.

CPU COMMAND (OBJECT 0X2051)	
COMMAND CODE	DESCRIPTION
0x5C0n	Force the preset value (object 0x2211) for counter n
0x5D0n	Force the reset for counter n
0x5E0n	Force the overflow reset (object 0x6000 sub 4)



Object 0X2200 is used to customize the input filter.

FILTER PARAMETERS (OBJECT 0X2200)	
SUBINDEX	DESCRIPTION
1	Samples Number for filter (default 40)
2	Counter threshold for high level (default 20)
3	Counter threshold for low level (default 20)

For a high level sample the filter counter is incremented, otherwise for a low level the filter counter is decremented.

When the filter counter is greater or equal subindex2 the input is stated "high".
 When the filter counter is lower or equal subindex3 the input is stated "low".
 In between subindex2 and subindex3 no state is asserted (dead zone).

Note that the filter can be disabled by selecting:
 Subindex 1 = 1
 Subindex 2 = 0
 Subindex 3 = 0

Object 0x2210 stores the values of the 8 counters in 32 bit format.

DIGITAL COUNTERS (OBJECT 0X2210)	
SUBINDEX	DESCRIPTION
1	Counter 1 Value
2	Counter 2 Value
3	Counter 3 Value
4	Counter 4 Value
5	Counter 5 Value
6	Counter 6 Value
7	Counter 7 Value
8	Counter 8 Value

DIGITAL COUNTERS (OBJECT 0X2210)	
SUBINDEX	DESCRIPTION
1	Preset Counter 1 Value
2	Preset Counter 2 Value
3	Preset Counter 3 Value
4	Preset Counter 4 Value
5	Preset Counter 5 Value
6	Preset Counter 6 Value
7	Preset Counter 7 Value

DIP-SWITCH CONFIGURATION

BAUD RATE (kbps)		ADDRESS	
1 2 3 SOFTWARE PROGRAMMED	4 5 6 7 8 9 10	0000000	SOFTWARE PROGRAMMED
CANopen	ModBus	0000001	ADD. 001
20	2.4	0000010	ADD. 002
50	4.8	0000011	ADD. 003
125	9.6	0000100	ADD. 004
250	19.2	0000101	ADD. 005
500	38.4
800	57.6
1000	115.2	1111111	ADD. 127

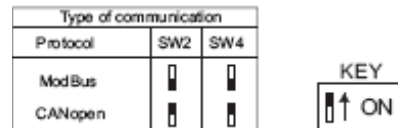

CANopen LED DESCRIPTION

INPUT/OUTPUT LED DESCRIPTION		
LED	STATE	DESCRIPTION
● 1...8	ON	Input [1..8] is high
	OFF	Input [1..8] is low
● 9...16	ON	Input [9..24] is high
	OFF	Input [9..24] is low
● 10...80	ON	Output [1..8] is high
	OFF	Output [1..8] is low



SERVICE (DIAGNOSTIC) LED DESCRIPTION		
LED	STATE	DESCRIPTION
● RUN	BLINKING	Pre-operational mode
	SINGLE FLASH	Stop mode
	ON	Operational mode
● ERROR	SINGLE FLASH	At least one error counter has reached or exceeded the warning level
	DOUBLE FLASH	GUARD Event
	TRIPLE FLASH	The SYNC hasn't received within the configured communication cycle timeout period
	ON	The CAN controller is bus OFF
	OFF	NO Error
● FAIL	ON BLINKING	Data receiving from RS232
● POWER	ON	Power Supply

CANopen DIGITAL INPUT MANAGEMENT

Object 0x6003 is used for Input Filter Configuration

FILTER CONSTANT INPUT (OBJECT 0X6003)	
SUBINDEX	DESCRIPTION
1	FILTER ENABLED FOR INPUT [1..8]
2	FILTER ENABLED FOR INPUT [9..16] READ ONLY

If the value of object 0x6003 subindex 1 is "0" all inputs from 1 to 8 are configured in counter mode, in other word counter mode switched ON.

If the value of object 0x6003 subindex 1 is not equal to "0" the counter mode is switched OFF.

Object 0x6005 is used for Interrupt Enable:
 If the value is "1" the station can generate a synchronous TxPDO (DEFAULT setting).
 If the value is "0" the station can't generate a synchronous TxPDO.

Object 0x6007 is used as Digital Interrupt Mask Low to Hgh.

IINTERRUPT MASK LOW TO HIGH (OBJECT 0X6007)	
SUBINDEX	DESCRIPTION
1	Interrupt mask on rising edge input [1..8]
2	Interrupt mask on rising edge input [9..16]
3	Interrupt mask for counters overflow

For subindex 1 and 2 if value is "1" than the generation of TxPDO on rising edge is enabled.

If subindex 3 value is "1" the generation of TxPDO on all 8 counters overflows is enabled.

Object 0x6007 is used as Digital Interrupt Mask Low to Hgh.

IINTERRUPT MASK HIGH TO LOW (OBJECT 0X6008)	
SUBINDEX	DESCRIPTION
1	Interrupt mask on falling edge input [1..8]
2	Interrupt mask on falling edge input [9..16]

For subindex 1 and 2 if value is "1" than the generation of TxPDO on falling edge is enable

CANopen DIGITAL OUTPUT MANAGEMENT

Object 0x6200 is used as 8 bit output

8 BIT OUTPUT (OBJECT 0X6200)	
SUBINDEX	DESCRIPTION
1	OUTPUT [1..8] VALUE

OUTPUT ERROR MODE (OBJECT 0X6206)	
SUBINDEX	DESCRIPTION
1	OUTPUT [1..8] ERROR MODE

If bit n (output n) is "0", this output keeps the last value;
 If bit n (output n) is "1", this output is loaded with object 0x6207.



Object 0x6207 is used to store outputs values to load, in FAULT case (only if in output error mode corresponding bit value is “1”).

OUTPUT ERROR VALUE (OBJECT 0X6207)	
SUBINDEX	DESCRIPTION
1	Interrupt mask on falling edsge input [1..8]
2	Interrupt mask on falling edsge input [9..16]
3	Interrupt mask on falling edsge input [17..24]

Object 0x6220 is used for outputs corresponding bits

OUTPUT SINGLE BIT (OBJECT 0X6220)	
SUBINDEX	DESCRIPTION
1	Output 1 value
2	Output 2 value
3	Output 3 value
4	Output 4 value
5	Output 5 value
6	Output 6 value
7	Output 7 value
8	Output 8 value



CANopen FUNCTIONAL DIAGRAM
COUNTER MODE ON (Subindex 1 Object 0x6003 = '0')

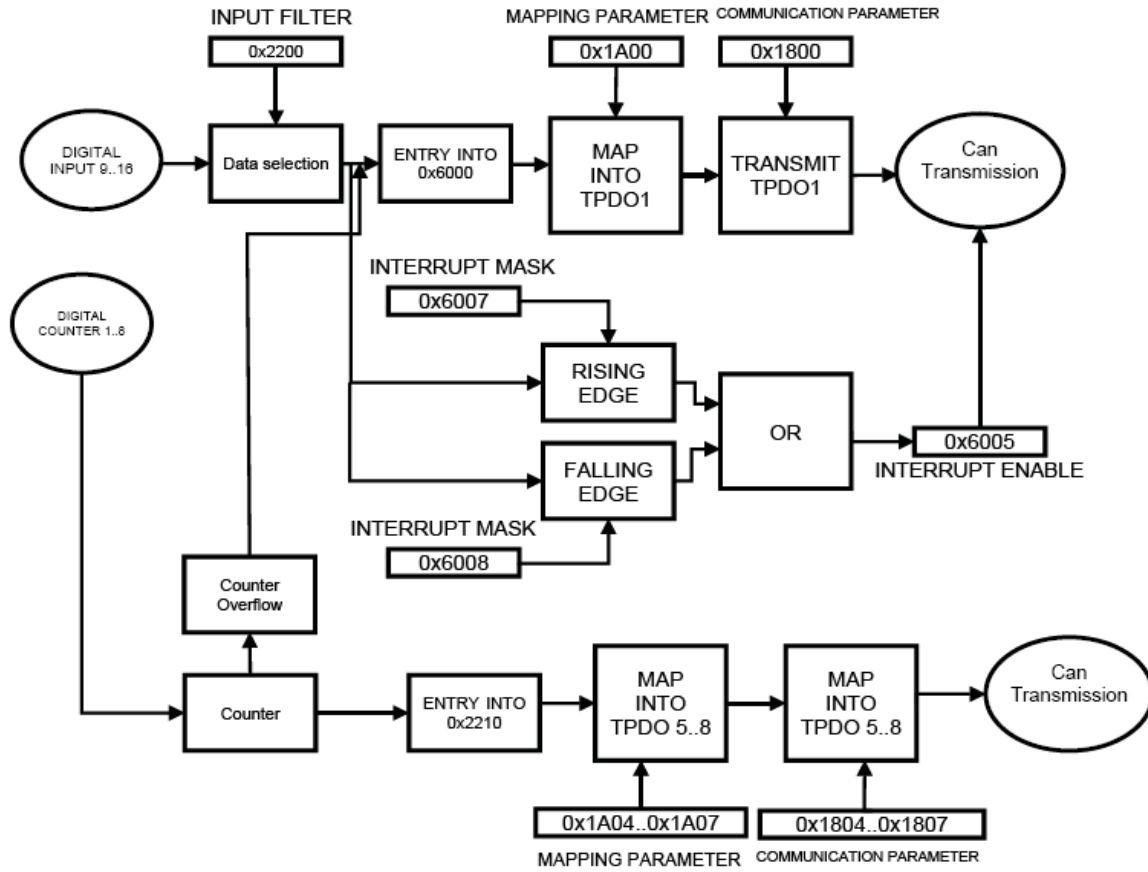



CANopen FUNCTIONAL DIAGRAM
DIGITAL OUTPUT

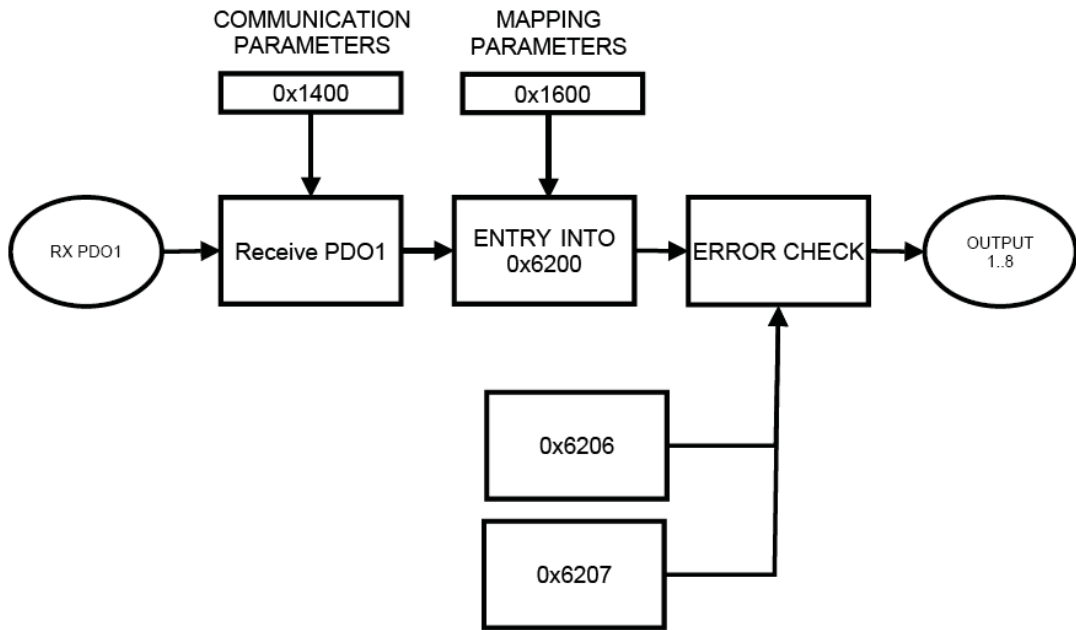



CANopen OBJECT DICTIONARY

Communication Profile Area

INDEX	SUB INDEX	NAME	DESCRIPTION	TYPE	ACCESS	DEFAULT
0x1000	0	Device Type	Device Type (Profile 401 = 0x191)	UNSIGNED 32	RO	0x0030191
0x1001	0	Error register	Error register (DS 401)	UNSIGNED 8	RO	0
0x1002	0	Manufacturer Status Register	Status Register	UNSIGNED 32	RO	0
0x1005	0	SYNC COB-ID	The device consumes the SYNC message	UNSIGNED 32	RW	0x80
0x1006	0	Communication Window Length	Sync interval [us]	UNSIGNED 32	RW	0
0x1007	0	Synchronous Window Length	Time window [us] for the PDO transmission after the SYNC	UNSIGNED 32	RW	0
0x1008	0	Manufacturer Device Name	Device name	VISIBLE STRING	RO	"ZC-16DI8DO"
0x1009	0	Manufacturer Hardware version	Hardware version	VISIBLE STRING	RO	"SC000000"
0x100A	0	Manufacturer Software version	Software version	VISIBLE STRING	RO	"SW001190"
0x100C	0	Guard Time	Guard Time [ms]	UNSIGNED 16	RW	0
0x100D	0	Life Time Factor	Max delay between two guarding telegrams = Guard_Time*Life_Time_Factor	UNSIGNED 8	RW	0
0x1010	0	Store Parameters	Max Subindex Number		RO	4
	1	Save All Parameters	Store not volatile parameters (Write in ASCII "save" for store process MSB 0x65766173 LSB)	UNSIGNED 32	RW	1
	2	Save Communication Parameters	Store not volatile parameters (Write in ASCII "save" for store process MSB 0x65766173 LSB)	UNSIGNED 32	RW	1
	3	Save Application Parameters	Store not volatile parameters (Write in ASCII "save" for store process MSB 0x65766173 LSB)	UNSIGNED 32	RW	1
	4	Save Manufactures Parameters	Store not volatile parameters (Write in ASCII "save" for store process MSB 0x65766173 LSB)	UNSIGNED 32	RW	1
0x1011	0	Restore Default	Max Subindex Number	UNSIGNED 8	RO	4
	1	Restore All Parameters	Restore not volatile parameters (Write in ASCII "load" for load process MSB 0x64616F6C LSB)	UNSIGNED 32	RW	0
	2	Restore Communication Parameters	Restore not volatile parameters (Write in ASCII "load" for load process MSB 0x64616F6C LSB)	UNSIGNED 32	RW	0
	3	Restore Application Parameters	Restore not volatile parameters (Write in ASCII "load" for load process MSB 0x64616F6C LSB)	UNSIGNED 32	RW	0



INDEX	SUB INDEX	NAME	DESCRIPTION	TYPE	ACCESS	DEFAULT
	4	Restore Mnuufactures parameters	Restore not volatile parameters (Write in ASCII "load" for load process MSB 0x64616F6C LSB)	UNSIGNED 32	RW	0
0x1014	0	COB-ID Emergency Object	COB-ID for Emergency Object	UNSIGNED 32	RO	NODEID + 0x80
0x1018	0	Identity Object	Max Subindex Number	UNSIGNED 8	RO	4
	1	Vendor ID	Seneca srl	UNSIGNED 32	RO	0x00000249
	2	Product Code	ZC-16DI8DO Machine ID Code	UNSIGNED 32	RO	0x00000022
	3	Revision Number	Revision	UNSIGNED 32	RO	0
	4	Serial Number	Serial Number Code	UNSIGNED 32	RO	0
0x1200	0	Server SDO Parameters	Max Subindex Number	UNSIGNED 8	RO	2
	1	Receive SDO COB-ID	COB-ID of Receive SDO	UNSIGNED 32	RO	NODEID + 0x600
	2	Transmit SDO COB-ID	COB-ID of Transmit SDO	UNSIGNED 32	RO	NODEID+ 0x580
0X1400	0	Receive PDO1 Communication Parameters	Max Subindex Number	UNSIGNED 8	RO	3
	1	COB-ID	COB-ID of RxPDO1	UNSIGNED 32	RW	NODEID + 0x40000180
	2	Transmission Type	Transmission Type for RxPDO1 0x00 = Synchronous - acyclic 0x01 to 0xF0 = Synchronous-cyclic 0xFF = Asynchronous	UNSIGNED8	RW	0xFF
	3	Inhibit Time	Not used in Rx PDO	UNSIGNED 16	RW	0x0000
0x1600	0	Receive PDO1 Mapping	Max Subindex Number	UNSIGNED 8	RO	4
	1	Object NR1	First Object	UNSIGNED 32	RW	0x62000108 Object = 0x6000 Subindex = 1 Length = 8 bit
0x1800	0	Transmit PDO1 Communication Parameters	Max Subindex Number	UNSIGNED 8	RO	3
	1	COB-ID	COB-ID of TxPDO1	UNSIGNED 32	RW	NODEID + 0x40000180
	2	Transmission Type	Transmission Type for TxPDO1 0x00 = Synchronous - acyclic 0x01 to 0xF0 = Synchronous-cyclic 0xFF = Asynchronous	UNSIGNED 8	RW	0xFF
	3	Inhibit Time	Min. delay for the next PDO (ms/10)	UNSIGNED 16	RW	0x0000
0x1804	0	Transmit PDO5 Communication Parameters	Max Subindex Number	UNSIGNED 8	RO	3
	1	COB-ID	COB-ID of TxPDO5	UNSIGNED 32	RW	NODEID + 0x40000280



INDEX	SUB INDEX	NAME	DESCRIPTION	TYPE	ACCESS	DEFAULT
	2	Transmission Type	Transmission Type for TxPDO5 0x00 = Synchronous - acyclic 0x01 to 0xF0 = Synchronous-cyclic 0xFF = Asynchronous	UNSIGNED 8	RW	0x01
	3	Inhibit Time	Min. delay for the next PDO (ms/10)	UNSIGNED 16	RW	0x0000
0x1805	0	Transmit PDO6 Communication Parameters	Max Subindex Number	UNSIGNED 8	RO	3
	1	COB-ID	COB-ID of TxPDO6	UNSIGNED 32	RW	NODEID + 0x40000380
	2	Transmission Type	Transmission Type for TxPDO6 0x00 = Synchronous - acyclic 0x01 to 0xF0 = Synchronous-cyclic 0xFF = Asynchronous	UNSIGNED 8	RW	0x01
	3	Inhibit Time	Min. delay for the next PDO (ms/10)	UNSIGNED 16	RW	0x0000
0x1806	0	Transmit PDO7 Communication Parameters	Max Subindex Number	UNSIGNED 8	RO	3
	1	COB-ID	COB-ID of TxPDO7	UNSIGNED 32	RW	NODEID + 0x40000480
	2	Transmission Type	Transmission Type for TxPDO7 0x00 = Synchronous - acyclic 0x01 to 0xF0 = Synchronous-cyclic 0xFF = Asynchronous	UNSIGNED 8	RW	0x01
	3	Inhibit Time	Min. delay for the next PDO (ms/10)	UNSIGNED 16	RW	0x0000
0x1807	0	Transmit PDO1 Communication Parameters	Max Subindex Number	UNSIGNED 8	RO	3
	1	COB-ID	COB-ID of TxPDO1	UNSIGNED 32	RW	NODEID + 0x40000300
	2	Transmission Type	Transmission Type for TxPDO1 0x00 = Synchronous - acyclic 0x01 to 0xF0 = Synchronous-cyclic 0xFF = Asynchronous	UNSIGNED 8	RW	0x01
	3	Inhibit Time	Min. delay for the next PDO (ms/10)	UNSIGNED 16	RW	0x0000
0x1A00	0	Transmit PDO1 Mapping	Max Subindex Number	UNSIGNED 8	RO	4
	1	Object NR1	First Object (default: Input 1..8)	UNSIGNED 32	RW	0x60000108 Object = 0x6000 Subindex = 1 Length = 8 bit



INDEX	SUB INDEX	NAME	DESCRIPTION	TYPE	ACCESS	DEFAULT
	2	Object NR2	Second Object (default: Input 9..16)	UNSIGNED 32	RW	0x60000208 Object = 0x6000 Subindex = 2 Length = 8 bit
	3	Object NR3	Third Object (default: Counter 1..8 Overflow)	UNSIGNED 32	RW	0x60000308 Object = 0x6000 Subindex = 3 Length = 8 bit
0x1A04	0	Transmit PDO5 Mapping	Max Subindex Number	UNSIGNED 8	RO	2
	1	Object NR1	First Object (default:: Counter 1)	UNSIGNED 32	RW	0x22100120 Object = 0x2210 Subindex = 1 Length = 32 bit
	2	Object NR2	Second Object (default: Counter2)	UNSIGNED 32	RW	0x22100220 Object = 0x2210 Subindex = 2 Length = 32 bit
0x1A05	0	Transmit PDO6 Mapping	Max Subindex Number	UNSIGNED 8	RO	2
	1	Object NR1	First Object (default:: Counter 3)	UNSIGNED 32	RW	0x22100320 Object = 0x2210 Subindex = 3 Length = 32 bit
	2	Object NR2	Second Object (default: Counter 4)	UNSIGNED 32	RW	0x22100420 Object = 0x2210 Subindex = 4 Length = 32 bit
0x1A06	0	Transmit PDO7 Mapping	Max Subindex Number	UNSIGNED 8	RO	2
	1	Object NR1	First Object (default: Counter 5)	UNSIGNED 32	RW	0x22100520 Object = 0x2210 Subindex = 5 Length = 32 bit
	2	Object NR2	Second Object (default: Counter 6)	UNSIGNED 32	RW	0x22100620 Object = 0x2210 Subindex = 6 Length = 32 bit
0x1A07	0	Transmit PDO8 Mapping	Max Subindex Number	UNSIGNED 8	RO	2
	1	Object NR1	First Object (default:: Counter 7)	UNSIGNED 32	RW	0x22100720 Object = 0x2210 Subindex = 7 Length = 32 bit



INDEX	SUB INDEX	NAME	DESCRIPTION	TYPE	ACCESS	DEFAULT
	2	Object NR2	Second Object (default: Counter 8)	UNSIGNED 32	RW	0x22100820 Object = 0x2210 Subindex = 8 Length = 32 bit

Manufacturer Profile Area

INDEX	SUB INDEX	NAME	DESCRIPTION	TYPE	ACCESS	DEFAULT
0x2001	0	Module Address	Station Address (only if dip switch 4,5,6,7,8,9,10 are OFF)	UNSIGNED 8	RW	127
0x2002	0	Buad Rate	Station Baud Rate (only if dip switch 1,2,3 are OFF) 1 = 20Kbps 2 = 50Kbps 3 = 125Kbps 4 = 250Kbps 5 = 500Kbps 6 = 800Kbps 7 = 1Mbps	UNSIGNED 8	RW	7
0x2030	0	Device Temperature	Max Subindex Number	UNSIGNED 8	RO	4
	1	Internal Temperature	Station internal Temperature [°C/10]	INTEGER 16	RO	0
	2	Hi Hi Temperature	Critical Hot Temperature (All operations Stop) [°C/10]	INTEGER 16	RO	950
	3	Hi Temperature	Warning for Too Hot Temperature [°C/10]	INTEGER 16	RO	900
	4	Low Temperature	Critical Low Temperature (All operations Stop) [°C/10]	INTEGER 16	RO	-250
0x2051	0	CPU Command	Command to execute Supported commands are: 0x5Cnn Force preset for counter mask nn 0x5Dnn Force reset for counter mask nn 0x5Enn Force overflow for counter mask nn	UNSIGNED 16	RW	0
0x2052	0	Aux Command	Reserved	UNSIGNED 16	RW	0
0x2200	0	Input Filter Parameter	Max Subindex Number	UNSIGNED 8	RO	3
	1	Filter Length	Number of samples to evaluate	UNSIGNED 8	RW	40
	2	Counter threshold for high level	If counter >= threshold_high input is stated "high"	UNSIGNED 8	RW	20



INDEX	SUB INDEX	NAME	DESCRIPTION	TYPE	ACCESS	DEFAULT
	3	Counter threshold for low level	If counter <= threshold_low input is stated "low"	UNSIGNED 8	RW	20
0x2210	0	Input Counters	Max Subindex Number	UNSIGNED 8	RO	8
	1	Counter 1 Value	Counter 1 value	UNSIGNED 32	RW	0
	2	Counter 2 Value	Counter 2 value	UNSIGNED 32	RW	0
	3	Counter 3 Value	Counter 3 value	UNSIGNED 32	RW	0
	4	Counter 4 Value	Counter 4 value	UNSIGNED 32	RW	0
	5	Counter 5 Value	Counter 5 value	UNSIGNED 32	RW	0
	6	Counter 6 Value	Counter 6 value	UNSIGNED 32	RW	0
	7	Counter 7 Value	Counter 7 value	UNSIGNED 32	RW	0
	8	Counter 8 Value	Counter 8 value	UNSIGNED 32	RW	0
0x2211	0	Preset for Input Counters	Max Subindex Number	UNSIGNED 8	RO	8
	1	Counter 1 Preset Value	Counter 1 preset value	UNSIGNED 32	RW	0
	2	Counter 2 Preset Value	Counter 2 preset value	UNSIGNED 32	RW	0
	3	Counter 3 Preset Value	Counter 3 preset value	UNSIGNED 32	RW	0
	4	Counter 4 Preset Value	Counter 4 preset value	UNSIGNED 32	RW	0
	5	Counter 5 Preset Value	Counter 5 preset value	UNSIGNED 32	RW	0
	6	Counter 6 Preset Value	Counter 6 preset value	UNSIGNED 32	RW	0
	7	Counter 7 Preset Value	Counter 7 preset value	UNSIGNED 32	RW	0
	8	Counter 8 Preset Value	Counter 8 preset value	UNSIGNED 32	RW	0
0x2520	0	Output Status	Max Subindex Number	UNSIGNED 8	RO	1
	1	Output [1..8] Status	1 = Output status ERROR 0 = Output status OK	UNSIGNED 8	RW	0
0x2521	0	Output Fail type	Max Subindex Number	UNSIGNED 8	RO	1
	1	Fail type Output [1..8]	Reserved	UNSIGNED 32	RW	0



Standard Device Profile Area

INDEX	SUB INDEX	NAME	DESCRIPTION	TYPE	ACCESS	DEFAULT
0x6000	0	8 bit Digital Input Counter 1 overflow	Max Subindex Number	UNSIGNED 8	RO	3
	1	Input [1..8] Value	Read input [1..8] value	UNSIGNED 8	RO	0
	2	Input [9..16] Value	Read input [9..16] value	UNSIGNED 8	RO	0
	3	Counter [1..8] overflow	Overflow Status Counter [1..8]	UNSIGNED 8	RO	0
0x6003	0	Filter Mask Enable	Max Subindex Number	UNSIGNED 8	RO	2
	1	Input [1..8] Filter Mask Enable	Input [1..8] Filter enable Mask bit 0 = Filter disabled (and Counters 1..8 Enabled) Mask bit 1 = Filter enabled (and Counters 1..8 Disabled)	UNSIGNED 8	RW	0xFF
	2	Input [9..16] Filter Mask Enable	Input [9..16] Filter Mask enable	UNSIGNED 8	RO	0xFF
0x6005	0	Global Interrupt Enabled	0 = TxPDO Asynchronous disabled 1 = TxPDO Asynchronous enabled	UNSIGNED 8	RW	1
0x6007	0	Interrupt Mask Low to High	Max Subindex Number	UNSIGNED 8	RO	3
	1	Input [1..8] interrupt Low to High mask enable	Input [1..8] rising interrupt mask enable Mask bit 0 = rising interrupt disabled Mask bit 1 = rising interrupt enabled	UNSIGNED 8	RW	0xFF
	2	Input [9..16] interrupt Low to High mask enable	Input [9..16] rising interrupt mask enable Mask bit 0 = rising interrupt disabled Mask bit 1 = rising interrupt enabled	UNSIGNED 8	RW	0xFF
	3	Counter [1..8] Overflow interrupt mask enable	Counter [1..8] rising interrupt mask enable Mask bit 0 = rising interrupt disabled Mask bit 1 = rising interrupt enabled	UNSIGNED 8	RW	0xFF
0x6008	0	Interrupt Mask High to Low	Max Subindex Number	UNSIGNED 8	RO	2
	1	Input [1..8] interrupt High to Low mask enable	Input [1..8] falling interrupt mask enable Mask bit 0 = falling interrupt disabled Mask bit 1 = falling interrupt enabled	UNSIGNED 8	RW	0xFF
	2	Input [9..16] interrupt High to Low mask enable	Input [9..16] falling interrupt mask enable Mask bit 0 = falling interrupt disabled Mask bit 1 = falling interrupt enabled	UNSIGNED 8	RW	0xFF



INDEX	SUB INDEX	NAME	DESCRIPTION	TYPE	ACCESS	DEFAULT
0X6020	0	Read Input 1 Bit	Max Subindex Number	UNSIGNED 8	RO	16
	1	Input 1 Value	0 = Input is "Low" 1 = Input is "High"	UNSIGNED 8	RO	0
	2	Input 2 Value	0 = Input is "Low" 1 = Input is "High"	UNSIGNED 8	RO	0
	3	Input 3 Value	0 = Input is "Low" 1 = Input is "High"	UNSIGNED 8	RO	0
	4	Input 4 Value	0 = Input is "Low" 1 = Input is "High"	UNSIGNED 8	RO	0
	5	Input 5 Value	0 = Input is "Low" 1 = Input is "High"	UNSIGNED 8	RO	0
	6	Input 6 Value	0 = Input is "Low" 1 = Input is "High"	UNSIGNED 8	RO	0
	7	Input 7 Value	0 = Input is "Low" 1 = Input is "High"	UNSIGNED 8	RO	0
	8	Input 8 Value	0 = Input is "Low" 1 = Input is "High"	UNSIGNED 8	RO	0
	9	Input 9 Value	0 = Input is "Low" 1 = Input is "High"	UNSIGNED 8	RO	0
	10	Input 10 Value	0 = Input is "Low" 1 = Input is "High"	UNSIGNED 8	RO	0
	11	Input 11 Value	0 = Input is "Low" 1 = Input is "High"	UNSIGNED 8	RO	0
	12	Input 12 Value	0 = Input is "Low" 1 = Input is "High"	UNSIGNED 8	RO	0
	13	Input 13 Value	0 = Input is "Low" 1 = Input is "High"	UNSIGNED 8	RO	0
	14	Input 14 Value	0 = Input is "Low" 1 = Input is "High"	UNSIGNED 8	RO	0
	15	Input 15 Value	0 = Input is "Low" 1 = Input is "High"	UNSIGNED 8	RO	0
	16	Input 16 Value	0 = Input is "Low" 1 = Input is "High"	UNSIGNED 8	RO	0
0X6200	0	8 bit Output	Max Subindex Number	UNSIGNED 8	RO	1
	1	Output 1..8 Value	Output Value	UNSIGNED 8	RW	0
0X6206	0	Error Mode Output	Max Subindex Number	UNSIGNED 8	RO	1
	1	Error Mode Output [1..8]	"1" = Load object 0x6207 value "0" = Keep last	UNSIGNED 8	RW	0xFF
0X6207	0	Error Value Output	Max Subindex Number	UNSIGNED 8	RO	1
	1	Error Value Output [1..8]	Value to load in fail case [1..8]	UNSIGNED 8	RW	0x00
0x6220	0	Single bit Output	Max Subindex Number	UNSIGNED 8	RO	8
	1	Output 1 Value	Output1	BOOLEAN	RW	0
	2	Output 2 Value	Output2	BOOLEAN	RW	0
	3	Output 3 Value	Output3	BOOLEAN	RW	0
	4	Output 4 Value	Output4	BOOLEAN	RW	0
	5	Output 5 Value	Output5	BOOLEAN	RW	0
	6	Output 6 Value	Output6	BOOLEAN	RW	0



<i>INDEX</i>	<i>SUB INDEX</i>	<i>NAME</i>	<i>DESCRIPTION</i>	<i>TYPE</i>	<i>ACCESS</i>	<i>DEFAULT</i>
	7	Output 7 Value	Output7	BOOLEAN	RW	0
	8	Output 8 Value	Output8	BOOLEAN	RW	0



MODBUS FEATURES

TECHNICAL DATA	
BAUD RATE	2.4, 4.8, 9.6, 19.2, 38.57.6, 115.2 Kbits/s
COUNTERS NR/TYPER	8 (32 bit) from input 1..8
MAX FREQUENCY FOR COUNTERS	10 kHz

DIP-SWITCH CONFIGURATION

BAUD RATE (kbps)		ADDRESS									
1	2	3	SOFTWARE PROGRAMMED	4	5	6	7	8	9	10	SOFTWARE PROGRAMMED
<input type="checkbox"/>	<input type="checkbox"/>	<input type="checkbox"/>		<input type="checkbox"/>	<input type="checkbox"/>	<input type="checkbox"/>	<input type="checkbox"/>	<input type="checkbox"/>	<input type="checkbox"/>	<input type="checkbox"/>	0000000
<input type="checkbox"/>	<input type="checkbox"/>	<input type="checkbox"/>	CANopen	<input type="checkbox"/>	<input type="checkbox"/>	<input type="checkbox"/>	<input type="checkbox"/>	<input type="checkbox"/>	<input type="checkbox"/>	<input type="checkbox"/>	0000001
<input type="checkbox"/>	<input type="checkbox"/>	<input type="checkbox"/>	ModBus	<input type="checkbox"/>	<input type="checkbox"/>	<input type="checkbox"/>	<input type="checkbox"/>	<input type="checkbox"/>	<input type="checkbox"/>	<input type="checkbox"/>	ADD. 001
<input type="checkbox"/>	<input type="checkbox"/>	<input type="checkbox"/>	20	<input type="checkbox"/>	<input type="checkbox"/>	<input type="checkbox"/>	<input type="checkbox"/>	<input type="checkbox"/>	<input type="checkbox"/>	<input type="checkbox"/>	0000010
<input type="checkbox"/>	<input type="checkbox"/>	<input type="checkbox"/>	50	<input type="checkbox"/>	<input type="checkbox"/>	<input type="checkbox"/>	<input type="checkbox"/>	<input type="checkbox"/>	<input type="checkbox"/>	<input type="checkbox"/>	ADD. 002
<input type="checkbox"/>	<input type="checkbox"/>	<input type="checkbox"/>	125	<input type="checkbox"/>	<input type="checkbox"/>	<input type="checkbox"/>	<input type="checkbox"/>	<input type="checkbox"/>	<input type="checkbox"/>	<input type="checkbox"/>	0000011
<input type="checkbox"/>	<input type="checkbox"/>	<input type="checkbox"/>	250	<input type="checkbox"/>	<input type="checkbox"/>	<input type="checkbox"/>	<input type="checkbox"/>	<input type="checkbox"/>	<input type="checkbox"/>	<input type="checkbox"/>	ADD. 003
<input type="checkbox"/>	<input type="checkbox"/>	<input type="checkbox"/>	500	<input type="checkbox"/>	<input type="checkbox"/>	<input type="checkbox"/>	<input type="checkbox"/>	<input type="checkbox"/>	<input type="checkbox"/>	<input type="checkbox"/>	0000100
<input type="checkbox"/>	<input type="checkbox"/>	<input type="checkbox"/>	800	<input type="checkbox"/>	<input type="checkbox"/>	<input type="checkbox"/>	<input type="checkbox"/>	<input type="checkbox"/>	<input type="checkbox"/>	<input type="checkbox"/>	ADD. 004
<input type="checkbox"/>	<input type="checkbox"/>	<input type="checkbox"/>	1000	<input type="checkbox"/>	<input type="checkbox"/>	<input type="checkbox"/>	<input type="checkbox"/>	<input type="checkbox"/>	<input type="checkbox"/>	<input type="checkbox"/>	0000101
											ADD. 005
										
				<input type="checkbox"/>	<input type="checkbox"/>	<input type="checkbox"/>	<input type="checkbox"/>	<input type="checkbox"/>	<input type="checkbox"/>	<input type="checkbox"/>	1111111
											ADD. 127

Type of communication		
Protocol	SW2	SW4
ModBus	<input type="checkbox"/>	<input type="checkbox"/>
CANopen	<input type="checkbox"/>	<input type="checkbox"/>

ModBus TERMINATOR	
SW3	State
<input type="checkbox"/>	ENABLE
<input type="checkbox"/>	DISABLE

MODBUS LED DESCRIPTION

SERVICE LED DESCRIPTION			
LED	STATE	DESCRIPTION	
	RUN/TX	ON	Data Transmission
	ERR/RX	ON	Data Receiving
	FAIL	ON BLINKING	Data receiving from RS232
	POWER	ON	Power Supply

INPUT LED DESCRIPTION			
LED	STATE	DESCRIPTION	
	1...8	ON	Input [1..8] is high
		OFF	Input [1..8] is low
	9...24	ON	Input [9..24] is high
		OFF	Input [9..24] is low



MODBUS REGISTERS

Holding Registers

ADDRESS	REGISTER	DESCRIPTION	TYPE	ACCESS	DEFAULT
40001	MACH-ID/EXT_FW_REV	machine id = 0x20 ext revision 1	FLASH	R	0x2201
40002	FW_CODE	Seneca FW Code	FLASH	R	CODE
40003	INPUT 1..8	Input 1...8	RAM	R	0
40004	INPUT 9..16	Input 9...16	RAM	R	0
40005	OUTPUT 1..8	Output 1..8	RAM	R/W	0
40006	STATUS	Status	RAM	R	0
40007	OUTPUT STATUS 1..8	Output Status	RAM	R	0
40008	COUNTER_OVERFLOW	Counter overflow 1 = Enable, 0 = Disable	RAM	R	0
40009	COUNTER1_H	Counter1_high word	RAM	R	0
40010	COUNTER1_L	Counter1_low word	RAM	R	0
40011	COUNTER2_H	Counter2_high word	RAM	R	0
40012	COUNTER2_L	Counter2_low word	RAM	R	0
40013	COUNTER3_H	Counter3_high word	RAM	R	0
40014	COUNTER3_L	Counter3_low word	RAM	R	0
40015	COUNTER4_H	Counter4_high word	RAM	R	0
40016	COUNTER4_L	Counter4_low word	RAM	R	0
40017	COUNTER5_H	Counter5_high word	RAM	R	0
40018	COUNTER5_L	Counter5_low word	RAM	R	0
40019	COUNTER6_H	Counter6_high word	RAM	R	0
40020	COUNTER6_L	Counter6_low word	RAM	R	0
40021	COUNTER7_H	Counter7_high word	RAM	R	0
40022	COUNTER7_L	Counter7_low word	RAM	R	0
40023	COUNTER8_H	Counter8_high word	RAM	R	0
40024	COUNTER8_L	Counter8_low word	RAM	R	0
40025	PRESET_COUNTER1_H	Preset Counter value = 0	FLASH	R/W	0
40026	PRESET_COUNTER1_L		FLASH	R/W	0
40027	PRESET_COUNTER2_H	Preset Counter vallue = 0	FLASH	R/W	0
40028	PRESET_COUNTER2_L		FLASH	R/W	0
40029	PRESET_COUNTER3_H	Preset Counter vallue = 0	FLASH	R/W	0
40030	PRESET_COUNTER3_L		FLASH	R/W	0
40031	PRESET_COUNTER4_H	Preset Counter vallue = 0	FLASH	R/W	0
40032	PRESET_COUNTER4_L		FLASH	R/W	0
40033	PRESET_COUNTER5_H	Preset Counter vallue = 0	FLASH	R/W	0
40034	PRESET_COUNTER5_L		FLASH	R/W	0



ADDRESS	REGISTER	DESCRIPTION	TYPE	ACCESS	DEFAULT
40035	PRESET_COUNTER6_H	Preset Counter value = 0	FLASH	R/W	0
40036	PRESET_COUNTER6_L		FLASH	R/W	0
40037	PRESET_COUNTER7_H	Preset Counter value = 0	FLASH	R/W	0
40038	PRESET_COUNTER7_L		FLASH	R/W	0
40039	PRESET_COUNTER8_H	Preset Counter value = 0	FLASH	R/W	0
40040	PRESET_COUNTER8_L		FLASH	R/W	0
40041	ERROR MODE OUT 1..8	Output 1..8 Error Mode	FLASH	R/W	0xFF
40042	ERROR VALUE OUT 1..8	Output 1..8 Error Value	FLASH	R/W	0
40043	FILTER IN MASK [1..8]	Input 1..8 Filter Mask	FLASH	R/W	0xFF
40044	FILTER IN MASK [9..16]	Input 9..16 Filter Mask	FLASH	R	0xFF
40045	FILTER_SAMPLES_NR	Default filter: It operates for frequency > 100 Hz	FLASH	R/W	0x28
40046	FILTER_HIGH_SAMPLES	(0..255)	FLASH	R/W	0x14
40047	FILTER_LOW_SAMPLES	(0..255)	FLASH	R/W	0x14
40048	ADDR_CAN	CANOpen Address 127	FLASH	R/W	127
40049	BAUD_CAN	CANOpen Baudrate 20 kbps	FLASH	R/W	1
40050	ADDR/PARITY MODBUS	Modbus Address 1, no parity	FLASH	R/W	0x0100
40051	BAUD/DELAY MODBUS	Modbus Baudrate 38400, no delay	FLASH	R/W	0x0500
40052	MODBUS FAIL COMM MODE	Modbus communication monitoring result	FLASH	R/W	0
40053	MODBUS FAIL COMM TIMEOUT	Timeout for Modbus communication monitoring [1/10 s]	FLASH	R/W	100
40201	COMMAND	Command register	RAM	R/W	0
40202	COMMAND_AUX	Service register for command	RAM	R	0
40301	INPUT [1..16]		RAM	R	0



Status

This register contains the states of over-temperature and flash errors:

STATUS							
BIT7	BIT6	BIT5	BIT4	BIT3	BIT2	BIT1	BIT0
FLASH_ERROR	0	0	0	TEMP_ERROR	0	0	0

Filters

For a high input level the filter counter is incremented, otherwise for a low level the filter counter is decremented.

When the filter counter is greater or equal than

FILTER_HIGH_SAMPLE the input is stated "High".
 When the filter counter is lower or equal than FILTER_LOW_SAMPLE the input is stated "Low".
 Between FILTER_HIGH_SAMPLE and FILTER_LOW_SAMPLE no state is asserted (dead zone).

Note that the filter can be disabled by selecting:

FILTER_HIGH_SAMPLE_NR = 1
 FILTER_LOW_SAMPLE = 0
 FILTER_HIGH_SAMPLE = 0

Modbus FAIL Communication

During Modbus Communication, a traffic monitoring is improved; so, if for a fixed time (MODBUS FAIL TIMEOUT) there is no data transmission/reception and MODBUS FAIL COMM MODE = 1, the device is in FAIL condition and ERROR values are loaded

Command Modbus

COMMAND	
CODE	DESCRIPTION
0xBAB0	Save in FLASH
0xBCD0	Load DEFAULT
0x5Cnn	Force Preset of counters corresponding to bits nn. (Preset value is in registers 40030-40045)
0x5Dnn	Force Reset of counters corresponding to bits nn
0x5Enn	Force reset bit overflow (COUNTER_OVERFLOW) corresponding to bits nn
0x6BAC	DIP Read
0xC1A0	Reset Module

	MASK		nn (HEX)	
	Mask1	Mask2	nn1	nn2
Counter8	1XXX	XXXX	8	X
Counter7	X1XX	XXXX	4	X
Counter6	XX1X	XXXX	2	X
Counter5	XXX1	XXXX	1	X
Counter4	XXXX	1XXX	X	8
Counter3	XXXX	X1XX	X	4
Counter2	XXXX	XX1X	X	2
Counter1	XXXX	XXX1	X	1

EXAMPLES:

0x5D83 (Mask. 1000 0011) Reset Counters 8, 2 e 1
 0x5D5C (Mask: 0101 1100) Reset Counters 7,5,4 e 3
 0x5DFF (Mask 1111 1111) Reset all counters



Coil Registers

ADDRESS	REGISTER	DESCRIPTION	TYPE	ACCESS	DEFAULT
10001	INPUT1	Input1	RAM	R	0
10002	INPUT2	Input2	RAM	R	0
10003	INPUT3	Input3	RAM	R	0
10004	INPUT4	Input4	RAM	R	0
10005	INPUT5	Input5	RAM	R	0
10006	INPUT6	Input6	RAM	R	0
10007	INPUT7	Input7	RAM	R	0
10008	INPUT8	Input8	RAM	R	0
10009	INPUT9	Input9	RAM	R	0
10010	INPUT10	Input10	RAM	R	0
10011	INPUT11	Input11	RAM	R	0
10012	INPUT12	Input12	RAM	R	0
10013	INPUT13	Input13	RAM	R	0
10014	INPUT14	Input14	RAM	R	0
10015	INPUT15	Input15	RAM	R	0
10016	INPUT16	Input16	RAM	R	0
10017	OUTPUT1	Output1	RAM	R/W	0
10018	OUTPUT2	Output2	RAM	R/W	0
10019	OUTPUT3	Output3	RAM	R/W	0
10020	OUTPUT4	Output4	RAM	R/W	0
10021	OUTPUT5	Output5	RAM	R/W	0
10022	OUTPUT6	Output6	RAM	R/W	0
10023	OUTPUT7	Output7	RAM	R/W	0
10024	OUTPUT8	Output8	RAM	R/W	0