

Z-PC LINE COMMUNICATION DEVICES

ZC-107FO

Fiber Optic ↔ CAN bus converter



CE

Power Supply

12..40 Vdc or 12..28 Vac (50-60 Hz)

CAN interface

CANBUS 2.0 Protocol, max speed 1 Mbps, IDC 10 connector

Fiber Optic

Multimodal (62,5/125 o 50/125 μm), ST – ST connectors

Operating Temperature

-30..+60°C

Dimensions

17,5 x 100 x 112 mm (w x h x d)

Typical use

Isolator, repeater and coupler for CAN buses

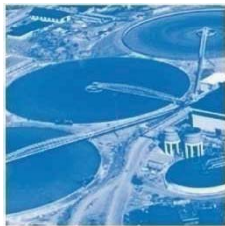

ZC-107FO

Fiber Optic ↔ CAN bus converter



ORDER CODE

| | | |
|--------------------|-------------------------|---|
| Model | ZC-107FO | Fiber Optic ↔ CAN serial converter |
| Accessories | Z-PC-DINAL2-17.5 | Terminal block for power / bus + 2 slot |
| | Z-PC-DIN2-17.5 | 2 slot block 17.5 mm |
| | Z-PC-DIN8-17.5 | 8 slot block 17.5 mm |

TECHNICAL SPECIFICATION

GENERAL FEATURES

| | |
|------------------------------|--|
| Power Supply | 12..40 Vdc, 12..28 Vac (50-60 Hz) |
| Power consumption | 1,2 W |
| Status indication | State, communication, functioning |
| Galvanic Isolation | 500 Vac input // power supply |
| Operating temperature | -30..+60 °C |
| Storage Temperature | -30..+85 °C |
| Humidity | 30..90% non condensing |
| Dimensions | 17,5 x 100 x 112 mm(w x h x d) |
| Weight | 140 g |
| Housing | PBT, black color |
| Mounting | DIN 46277 guide |
| Configuration | Via DIP-switches (baud rate, parity, serial port, bit stop, termination) |
| Conformity | CE, EN 61000-6-4, EN 64000-6-2, EN 61010-1, EN 60742 |

FIBER OPTIC

| | |
|----------------------|----------------------------------|
| Type | Multimodal(62,5/125 o 50/125 μm) |
| Connectors | ST / ST Frontal connectors |
| Delay message | 300 μs |
| Max distance | 2 km |

CAN INTERFACE

| | |
|-------------------|------------------------------------|
| Protocol | CANBUS 2.0 |
| Max speed | 1 Mbps |
| Terminals | Screws, removables, 3 way, 5,08 mm |
| Connectors | IDC10 back connectors (Din guide) |

CONNECTIONS, INSTALLATION, LAYOUT

Power supply by IDC10 back connector

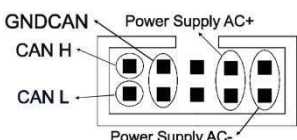

Backplane for din guide

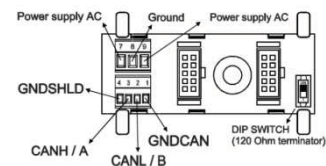

CAN port

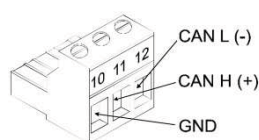

Power through terminals

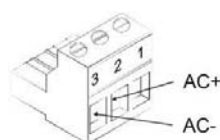

Application example

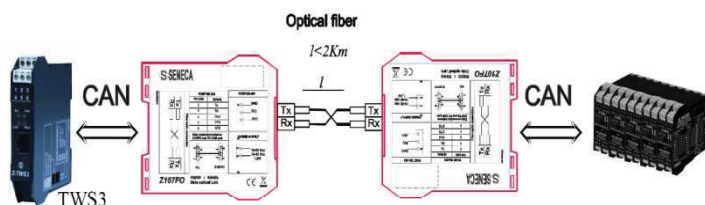

CAN line

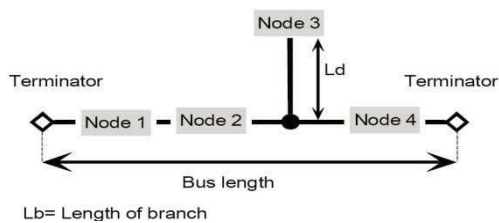

Application example

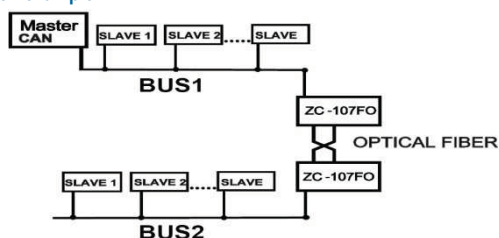

Mounting on DIN guide

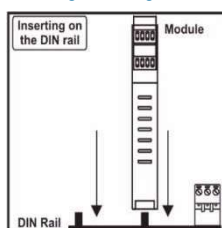

Layout

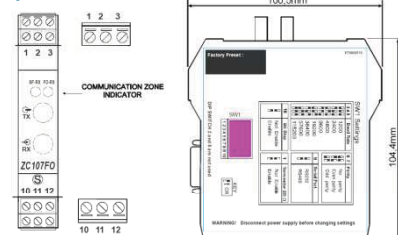

Installation Manual

| Contents: | Pag |
|-------------------------------|-----|
| - General description | 2 |
| - General features | 2 |
| - Technical specifications | 2 |
| - Installation Standards | 4 |
| - Electrical connections | 5 |
| - CANopen connection standard | 5 |
| - Main component position | 6 |
| - CANopen application example | 6 |
| - Connection examples | 7 |
| - Led status message | 7 |
| - DIP-switch setting | 8 |
| - Accessories | 8 |



SENECA s.r.l.
Via Germania, 34 - 35127 - Z.I. CAMIN - PADOVA - ITALY
Tel. +39.049.8705355 - 8705359 - Fax +39.049.8706287
e-mail: info@seneca.it - www.seneca.it

This document is property of SENECA srl. Duplication and reproduction are forbidden, if not authorized. Contents of the present documentation refers to the products and technologies described in it. All technical data contained in the document may be modified without prior notice. Content of this documentation is subject to periodical revision.

| PARAMETERS OPTICAL FIBER | |
|--------------------------|---|
| Type | Multimodal optical-fiber (62.5/125 o 50/125 micron) |
| Plug-in | Frontal connector ST-ST. |
| ENVIRONMENTAL CONDITION | |
| Operating temperature | -30..+60 °C |
| Storage temperature | -30..+85 °C |
| Humidity | 30 .. 90 % non-condensing |
| Altitude | Up to 2000m asl |
| CONNECTIONS | |
| Terminal Block | Removable 3-way screw terminals, 5,08 mm pitch |
| Rear connector | IDC10 for DIN Rail socket (Z-PC-DIN) |
| Size and weight | 100 x 112 x 17,5 mm; 140 g |
| Case | PBT, black |
| ISOLATIONS/STANDARDS | |
| Standards | EN61000-6-4/2007 (electromagnetic emission, industrial environment) EN61000-6-2/2005 (electromagnetic immunity, industrial environment) EN61010-1/2001 (safety). <i>All circuits must be insulated from the other circuits under dangerous voltage with double insulation. The power supply transformer must comply with EN60742: "Insulated transformers and safety transformers"</i> |



| CAN connections standard | | |
|--|------------|---------------|
| 1) Install the modules on the DIN rail (max 120). | | |
| 2) Connect the remote modules using cables of proper length. On the table following data about the cables length are provided: | | |
| - <i>Bus Length</i> : CAN network maximum length as a function of the Baud rate. It is the length of the cables which connects the two bus terminators modules (see <i>Scheme 1</i>). | | |
| - <i>Drop Length</i> : maximum length of a drop line (see <i>Scheme 1</i>) as a function of the Baud Rate. | | |
| Baud rate | Bus length | Branch length |
| 20 kbps | 2500 m | 150 m |
| 50 kbps | 1000 m | 60 m |
| 125 kbps | 500 m | 5 m |
| 250 kbps | 250 m | 5 m |
| 500 kbps | 100 m | 5 m |
| 800 kbps | 50 m | 3 m |
| 1000 kbps | 25 m | 0,3 m |
| | | |
| For the best performances, the use of special shielded cables is recommended (BELDEN 9841 cable for example). | | |
| 3) CANbus net must be terminated setting to the ON position the DIP-switch on the Z-PC-DINAL accessory. | | |
| CAN PORT | | |
| | | |
| The terminal block (10,11,12) may be the alternative to the rear connector (IDC10) for CAN port wiring. For the best performances, the use of special shielded cables is recommended. | | |
| POWER SUPPLY PORT | | |
| | | |
| The terminal block (2,3) may be the alternative to the rear connector (IDC10) for power supply wiring. | | |

| Connections example | | | |
|---|-------------------|------------------|---|
| CAN user example | | | |
| | | | |
| Led status message | | | |
| LED SP-Rx and FO-Rx : status communication | | | |
| In the table below there is a description of SP-Rx and FO-Rx. | | | |
| Meaning of Led SP-Rx (Red) | | | |
| N° | Led SP-Rx | STATUS | DESCRIPTION |
| 1 | OFF | No communication | a)The parameters of communication are wrong (see the DIP SWITCH settings). b)The connections of communication are wrong (see connection standards) |
| 2 | Blinking | Communication | The CAN communication work properly. |
| Meaning of Led FO-Rx (Red) | | | |
| N° | Led FO-Rx (Verde) | STATUS | DESCRIPTION |
| 1 | OFF | No communication | The device can't be connected properly.. |
| 2 | blinking | Communication | The communication packet was received correctly from optical-fiber. |
| The ZC-107FO internally has a green led that blinks when the power supply and communication functioning properly. | | | |

| General description | |
|---|--|
| The ZC-107FO is a CAN signal repeater through optical fiber. The device can be used to increase a number of nodes connection into the same logical bus, and its length can be extended up to 2 Km even at 1 Mb data rate. | |

| General features | |
|------------------|--|
| HW | <ul style="list-style-type: none"> Optical fiber communication up to 2 Km. 500 VAC isolation between input and power supply. Simplified assembly trough DIN rail socket. Power supply 12-40 Vdc or 12-28 Vac. Operating temperature -30°C/60°C. Operating status shows by frontal LED. Possibility of communication between different Baud Rate. 300us delay repetition message. |
| SW | <ul style="list-style-type: none"> Communication configuration settings from Dip switch. Maximum Baud rate: 1Mbps. Communication interface CAN protocol with CANBUS 2.0A: Transmission rate up to 1Mbps. Baud rate configuration from Dip Switch. Possible conversion of transmission rate communication. |

| Technical Specification | |
|-------------------------|----------------------------------|
| POWER SUPPLY | |
| Voltage | 12-40 Vdc or 12-28 Vac(50-60 Hz) |
| Consumption | 1,2 Watt max. |

| Installation Rules | |
|--|--|
| The module is designed to be installed in vertical position on a DIN 46277 rail. In order to ensure optimum performance and the longest working life, the module(s) must be supplied adequate ventilation and no raceways or other objects that obstruct the ventilation slots. Never install modules above sources of heat; we recommend installation in the lower part of the control panel. | |
| Inserting on the DIN rail as it is illustrated in the figure: | |
| 1) Insert the rear IDC10 connector on a free DIN rail socket slot (the inserting is univocal since the connectors are polarized). | |
| 2) Tighten the two locks placed at the sides of the rear connector to fix the module. | |
| | |

| Electrical connections | |
|---|--|
| POWER SUPPLY AND CAN INTERFACE | |
| Power Supply and Can interface are available also by using the Seneca DIN rail, by the rear IDC10 connector or by Z-PC-DINAL-A/B accessory. | |
| Rear Connector (IDC10) | |
| | In the figure the meaning of the IDC10 connector pins is showed, in the case the user decides to provide the signals directly through it. |
| Z-PC-DINAL-A / Z-PC-DINAL-B Accessories Use | |
| | In case of Z-PC-DINAL-A/B accessory use, the signals may be provided by terminal blocks. The figure shows the meaning of the terminals and the position of the DIP-switch (present on each DIN rail supports listed on <i>Accessories</i>) for CAN network termination. |
| GNDSHLD : Shield to protect the connection cables (always recommended). | |

| Main components position | |
|---|--|
| TERMINAL BLOCKS / LEDS / CONNECTOR / DIP-SWITCH | |
| The terminals numbering, the leds position on the frontal panel, the rear IDC10 connector for DIN rail and the DIP-switch on the rear side are illustrated below. | |
| | |

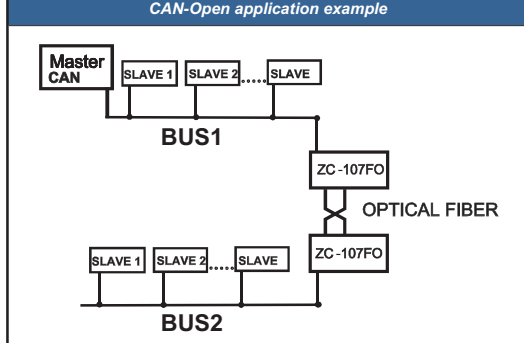

| Dip-Switch setting | | | | | | | | | | | | | | | | | | | | | | | | | | | | | | | | | | | | | | | | | | | | | |
|---|---|----------|--------------------|---|--------------------|---------|---------|---|------------|---------|---------|---|--------|---------|---------|--|--|---------|-----------|--|--|---------|----------|--|--|---------|----------|--|--|---------|----------|--|--|---------|----------|--|--|---------|----------|--|--|---------|-----------|--|--|
| The DIP-switches position defines the module CAN communication parameters: Address and Baud Rate. In the following figure the Baud Rate and Address values are listed as a function of the DIP-switches position: | | | | | | | | | | | | | | | | | | | | | | | | | | | | | | | | | | | | | | | | | | | | | |
| | <table border="1"> <thead> <tr> <th>7 8 9 10</th> <th>Baud Rate</th> <th>2</th> <th>Terminator 120 ohm</th> </tr> </thead> <tbody> <tr> <td>0 0 0 0</td> <td>10 kbps</td> <td>0</td> <td>Not Enable</td> </tr> <tr> <td>0 0 0 1</td> <td>20 kbps</td> <td>1</td> <td>Enable</td> </tr> <tr> <td>0 0 1 0</td> <td>50 kbps</td> <td></td> <td></td> </tr> <tr> <td>0 0 1 1</td> <td>62.5 kbps</td> <td></td> <td></td> </tr> <tr> <td>0 1 0 0</td> <td>100 kbps</td> <td></td> <td></td> </tr> <tr> <td>0 1 0 1</td> <td>125 kbps</td> <td></td> <td></td> </tr> <tr> <td>0 1 1 0</td> <td>250 kbps</td> <td></td> <td></td> </tr> <tr> <td>0 1 1 1</td> <td>500 kbps</td> <td></td> <td></td> </tr> <tr> <td>1 0 0 0</td> <td>800 kbps</td> <td></td> <td></td> </tr> <tr> <td>1 0 0 1</td> <td>1000 kbps</td> <td></td> <td></td> </tr> </tbody> </table> | 7 8 9 10 | Baud Rate | 2 | Terminator 120 ohm | 0 0 0 0 | 10 kbps | 0 | Not Enable | 0 0 0 1 | 20 kbps | 1 | Enable | 0 0 1 0 | 50 kbps | | | 0 0 1 1 | 62.5 kbps | | | 0 1 0 0 | 100 kbps | | | 0 1 0 1 | 125 kbps | | | 0 1 1 0 | 250 kbps | | | 0 1 1 1 | 500 kbps | | | 1 0 0 0 | 800 kbps | | | 1 0 0 1 | 1000 kbps | | |
| 7 8 9 10 | Baud Rate | 2 | Terminator 120 ohm | | | | | | | | | | | | | | | | | | | | | | | | | | | | | | | | | | | | | | | | | | |
| 0 0 0 0 | 10 kbps | 0 | Not Enable | | | | | | | | | | | | | | | | | | | | | | | | | | | | | | | | | | | | | | | | | | |
| 0 0 0 1 | 20 kbps | 1 | Enable | | | | | | | | | | | | | | | | | | | | | | | | | | | | | | | | | | | | | | | | | | |
| 0 0 1 0 | 50 kbps | | | | | | | | | | | | | | | | | | | | | | | | | | | | | | | | | | | | | | | | | | | | |
| 0 0 1 1 | 62.5 kbps | | | | | | | | | | | | | | | | | | | | | | | | | | | | | | | | | | | | | | | | | | | | |
| 0 1 0 0 | 100 kbps | | | | | | | | | | | | | | | | | | | | | | | | | | | | | | | | | | | | | | | | | | | | |
| 0 1 0 1 | 125 kbps | | | | | | | | | | | | | | | | | | | | | | | | | | | | | | | | | | | | | | | | | | | | |
| 0 1 1 0 | 250 kbps | | | | | | | | | | | | | | | | | | | | | | | | | | | | | | | | | | | | | | | | | | | | |
| 0 1 1 1 | 500 kbps | | | | | | | | | | | | | | | | | | | | | | | | | | | | | | | | | | | | | | | | | | | | |
| 1 0 0 0 | 800 kbps | | | | | | | | | | | | | | | | | | | | | | | | | | | | | | | | | | | | | | | | | | | | |
| 1 0 0 1 | 1000 kbps | | | | | | | | | | | | | | | | | | | | | | | | | | | | | | | | | | | | | | | | | | | | |
| N.B. The DIP-SWITCH 1,3,4,5 and 8 are not used. | | | | | | | | | | | | | | | | | | | | | | | | | | | | | | | | | | | | | | | | | | | | | |

| Accessories | |
|---|--|
| SUPPORTS FOR MOUNTING ON DIN RAIL GUIDE/ SERIAL CABLE | |
| Codice | Descrizione |
| Z-PC-DINAL-A | Bus Support: Terminal blocks + 2 slots to connect Z-PC line modules. |
| Z-PC-DINAL-B | Bus Support: Terminal blocks + 1 slot to connect Z-PC line modules. |
| Z-PC-DIN-2A | Bus Support: 2 slots to connect Z-PC line modules. |
| Z-PC-DIN-2B | Bus Support: 1 slots to connect Z-PC line modules. |
| Z-PC-DIN-8-A | Bus Support: 8 slots to connect Z-PC line modules. |
| Z-PC-DIN-8-B | Bus Support: 4 slots to connect Z-PC line modules. |
| Z-PC-FO | F.O. cable with ST/ST connection, L=2m |

Disposal of Electrical & Electronic Equipment (Applicable throughout the European Union and other European countries with separate collection programs). This symbol, found on your product or on its packaging, indicates that this product should not be treated as household waste when you wish to dispose of it. Instead, it should be handed over to an applicable collection point for the recycling of electrical and electronic equipment. By ensuring this product is disposed of correctly, you will help prevent potential negative consequences to the environment and human health, which could otherwise be caused by inappropriate disposal of this product. The recycling of materials will help to conserve natural resources. For more detailed information about the recycling of this product, please contact your local city office, waste disposal service or the retail store where you purchased this product.