

# Z-DAQ

## UNIVERSAL INPUT MODULE / RS485

Used for interfacing transducers and instruments with different standards of analogue signals to all of the control systems that are able to communicate with the transmission protocol MODBUS RTU through the RS485 serial interface.

The innovation introduced by the Z-DAQ is the universality of the input stage which allows the following signals to be accepted :

- Thermocouples J, K, R, S, T, E, B and N
- Thermo-resistances Ni100 - PT100 of 3 / 4 wires
- Signals in ohm (potentiometers)
- Signals in current : up to 20 Ma
- Signals in voltage : up to 10 V

Frontal signalling LEDs for: presence of power supply, setting error, out-of-scale and faulty sensor, reception/transmission of data.

The wiring of the power supply and serial bus is facilitated by the use of a support bus that can be lodged within the DIN guide. Such a system also allows for hot swapping, that is, the insertion and extraction of the module from the bus without the interruption of the communication nor the power supply to the remaining part of the system.

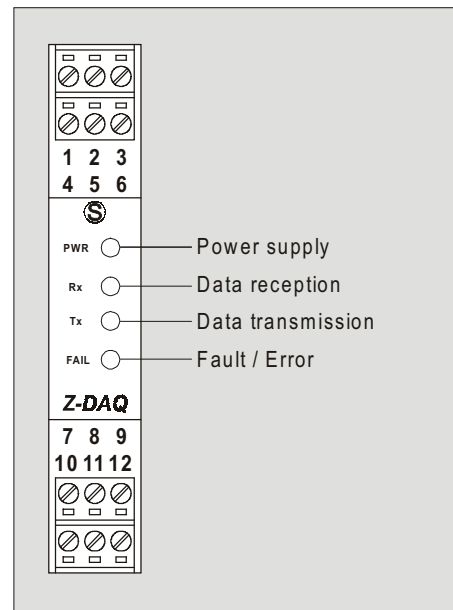

### TECHNICAL DATA

6

- Power supply : 19 - 40 Vcc / 19 - 28 Vca - 50/60 Hz, power consumption max. 2,5W
- Input galvanised separation (the remaining circuits are at low voltage) : 1500 Vac
- Interface : serial RS485 2 wire with settable velocity : 4800, 9600, 19200, 38400, 57600 baud
- Communication protocol : MODBUS RTU
- Communication time : < 20 ms (@ 38400 baud)
- Connection distance : up to 1200 m
- Sampling time : 300 ms
- Multi-scale universal input :
- Resolution : 0,1 °C for thermocouplese and thermal resistances, 10000 points for resistance, 10000 bi-polar poits for current and voltage
- Input impedance :2,5 ohm for current input, 1 Mohm for voltage input
- Precision :look at manual instruction
- Input protection : 60 V continuous
- Transducer power supply : min. 18Vdc 20mA
- *For further information make reference to page 2.*

**POWER SUPPLY**

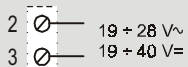

Power voltage must be in a range from 19 to 40 Vdc (indifferent polarity), from 19 to 28 Vac. **Upper limits must be exceeded, if it happen there could be damage for module.** It is necessary to protect power source from possible module's failure by fuse correctly dimensioned.

**CURRENT INPUT**

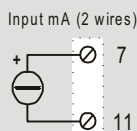
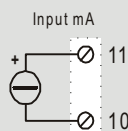

**VOLTAGE INPUT**

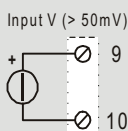

**THERMOCOUPLE INPUT**

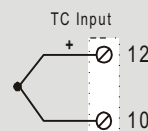

**RTD / POTENTIOMETER INPUT**

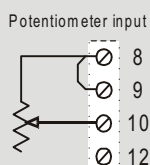
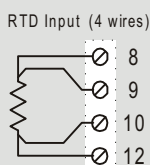
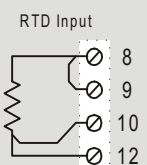

**SERIAL INTERFACE**

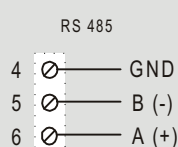

**BUS SUPPORT DIN TYPE**

The connection, for serial interface and feed of the module, is also situated on the connector on the instrument bottom.

This connector allows the connectin by bus through the support that must be installed in the DIN guide.

7

**PROGRAMMING**

All of the settings of the module, such as the type of input, setting of the digital filters, velocity of the serial interface, address of the module, etc. can be configured by means of the appropriate Z-PROG software.

**EXAMPLES**

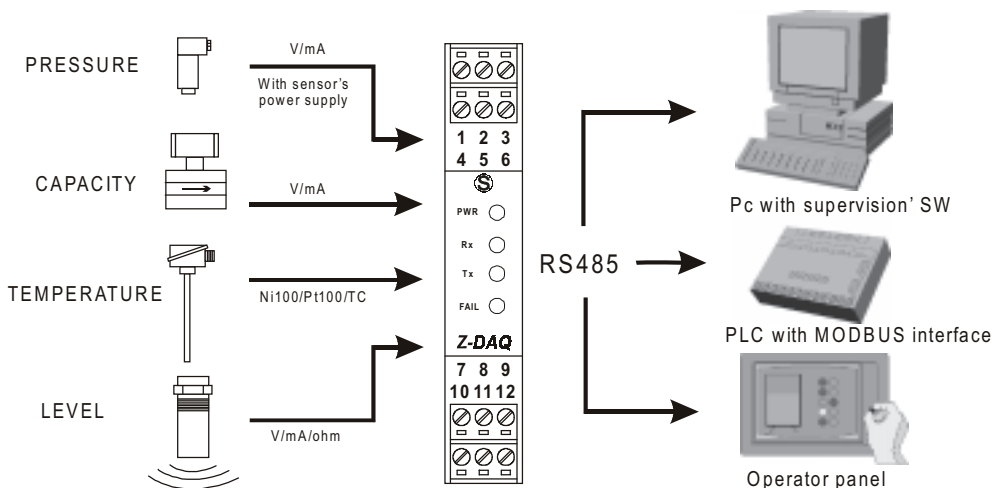

# Universal analogue input acquisition module Z-DAQ

## **GENERAL SPECIFICATIONS**

- Programmable universal input: voltage, current, resistance, thermoresistances, thermocouples.
- Sampling time 300 ms.
- Input protection up to 60 V (excluding mA input).
- 1500Vac input insulation with respect to remaining low voltage circuits.
- Possibility of power supply and serial bus facilitated wiring by means of a bus that can be housed in the DIN guide alternatively to the terminals.
- RS485 serial communication with MODBUS – RTU protocol, maximum 32 nodes.
- Insertion in and removal from bus without interruption of bus communication or power supply.
- Communication times below 20 ms (@ 38400 baud).
- Connection distance up to 1200 m.

## **TECHNICAL SPECIFICATIONS**

Power supply:	<b>19–40 Vdc, 19–28 Vac 50-60Hz, max 2.5W; 1.6W @ 24 Vdc.</b>			
Communication port:	2 wire RS485 serial with settable speed: 9600, 19200, 38400, 57600 baud.			
Protocol:	Modicon MODBUS – RTU.			
Voltage input:	two-pole with f.s. 50 mV, 200 mV, 2V, 5V and 10 V, input impedance 1 Mohm, resolution 0.01%.			
Current input:	two-pole with f.s. 20 mA, with loop power supply, input impedance < 5 ohm, resolution 0.01%.			
Input PT100 / NI100: (RTD)	3/4 wire measurement, range –200..+600 °C (NI100: -60..+180 ), energising current 0.56mA, resolution 0.1 °C, cable interruption or RTD detection.			
Thermocouple input:	type J,K,R,S,T,B,E,N; resolution 5uV, TC interruption detection.			
Potentiometer input:	up to 15000 ohm on 3 scales 0-3500, 0-8700,0-15000, resolution 0.01%, energising current 0.56 mA.			
Errors:	<b>Calibration</b>	<b>Linearity</b>	<b>Thermal stability</b>	<b>Other</b>
Voltage / Current	0.1% o.r.	0.05%	0.02%/°C	1% o.s. (3)
Resistance:	0.2% o.r.	0.05%	0.02%/°C	1% o.s. (3)
Thermoresistance:	0.2% o.r.	0.2 °C	(0.015+0.01% o.r.) °C/°C	0.1 °C + 1% o.s. (3)+(1)
Thermocouples J,K,E,T	0.2% o.r.	1 °C beyond 0 °C	0.02%/°C	1% o.s. (3)+(2)
Thermocouples R,S	0.2% o.r.	1 °C beyond 250 °C	0.02%/°C	1% o.s. (3)+(2)
Thermocouple B	0.2% o.r.	3 °C beyond 600 °C	0.02%/°C	1% o.s. (3)+(2)
Cold junction compensation	2 °C between 10 and 40 °C ambient			
Ambient conditions:	Temperature: 0..55 °C, min. humidity: 30%, max 90% at 40 °C non-condensing			
Protection rating:	IP20			
Weight, dimensions:	140g, 100 x 112 x 17.5 mm			
Standards	 <p>The instrument complies with the following standards:            EN50081-2 (electromagnetic emission, industrial environment)            EN50082-2 (electromagnetic immunity, industrial environment)            EN61010-1 (safety)            All the circuits must be provided with double insulation against circuits under dangerous voltage. The power supply transformer must comply with EN60742 standards for insulation transformers and safety transformers.</p>			

(1) influence of cable resistance 0.005%/ohm max 10ohm

(2) influence of cable resistance 0.5uV/ohm

(3) for possible electromagnetic interference

## ***INSTALLATION***

The Z-DAQ module is designed to be fitted on DIN 46277 guide, in a vertical position. For optimal operation and long life, adequate ventilation must be provided for the module(s), avoiding positioning channels that obstruct the ventilation louvers. Avoid fitting modules above equipment that generates heat; you are advised to fit them at the bottom of the panel.

### **HARSH OPERATING CONDITIONS:**

When the modules are fitted side by side it may be **necessary to separate them by at least 5 mm** if the panel temperature is above 45°C and operating conditions are harsh.

The following constitute harsh operating conditions:

- High power supply voltage (> 30Vdc / > 26 Vac).
- Loop power supply 4..20 mA input.

**NOTE:** Use of the DIN guide connectors supplied on request ensures practical fitting and correct ventilation of the modules, in addition to reducing the number of electrical cables.

## ***ELECTRICAL CONNECTIONS***

### **POWER SUPPLY**

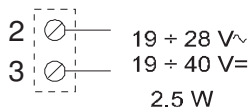

The power supply voltage must be between 19 and 40 Vdc (any polarity) or 19 and 28 Vac; see also section ***INSTALLATION***.

**The upper limits must not be exceeded as this can seriously damage the module.**

The power supply source must be protected from any failures in the module by means of a suitably sized fuse. The module can be powered via the DIN guide connectors.

### **INPUTS/ OUTPUTS**

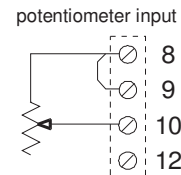
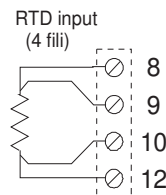
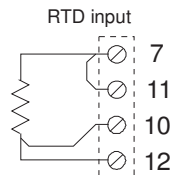
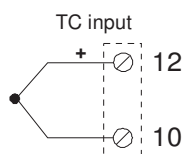
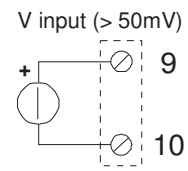
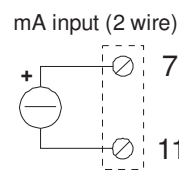
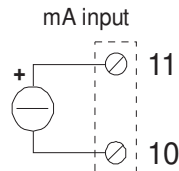
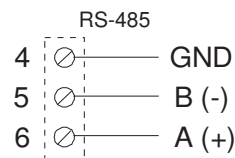

### **CAUTION:**

For voltage measurements with scale end below or equal to 50 mV, the **TC input** must be used.

## ***SERIAL INTERFACE***

The RS485 serial interface is based on a balanced differential communication line with typical impedance of 120 ohm. The maximum length of the connection is not defined but depends on the communication speed, the signal-interference ratio and the cable quality.

Generally the maximum length with guaranteed operation is fixed at 1200 m. The connection cable does not have to be shielded if the distance is only a few metres in a "low noise" electrical environment. For distances between 15 and 100 m a shielded twisted cable can be used without particular specifications whereas for connections over 100 m you are advised to use, for example, CEAM CPR 6003 or BELDEN 9841 cable.

The communication line should preferably be of the chain type, avoiding star configurations and limiting branches to a few metres (see figure below). The ends of the line must be terminated by setting the related dip-sw on the module to ON, or by fitting a resistance of 120 ohm parallel to the line.

The cable shield must be connected to the **GND** terminal on both sides, and connected to earth on at least one side. If necessary to reduce interference, the other side should be connected to earth by means of a 10 nF capacitor.

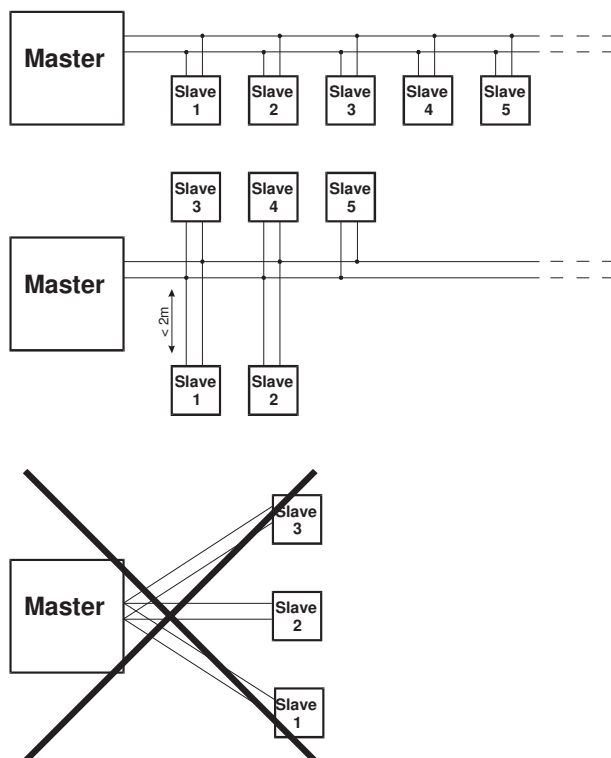

## SETTING THE DIP-SWITCHES

One side of the module features the dip-switches which are useful for selecting the following functions:

### Communication parameter selection:



The fixed setting parameters (dip-switch1=OFF) are:

**Address=001 , Baud Rate=9600**

During the first programming it is possible to use the settings from EEPROM (dip-switch **ON**) which are programmed originally with **Address=001** and **Baud Rate=38400**.

Other configuration parameters are fixed. **PARITY = none, NUMBER of BIT = 8, STOP BIT = 1.**

When reprogramming the module (when address and speed are not known, for example) it is possible to use the default position that sets the fixed parameters visible in the box.

NOTE: At the end of programming, the dip-switch1 must be set to **ON** and the module re-set.

### RS485 line termination:

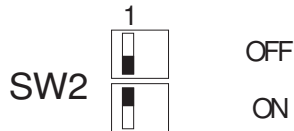

The RS485 line must be terminated only at the ends of the communication line.

### Reserved positions:



These dip-switch positions are reserved for future use.

## **MODBUS REGISTERS**

Below, the numerical values are decimals unless indicated otherwise by the prefix '0x' for hexadecimal values or '0b' for binary values. The suffix (H) indicates the upper part of a word and (L) indicates the lower part.

### **MODBUS COMMANDS SUPPORTED**

Command code	Description
3 - Read Holding Register	Permits reading of the <b>RAM and EEPROM</b> registers up to a <b>maximum of 12</b> at a time.
6 - Preset Single Register	Permits writing of the <b>RAM and EEPROM</b> registers individually.
16 - Preset Multiple Register	Permits writing of the <b>RAM</b> registers up to a <b>maximum of 10</b> at a time.

The following table lists and describes the Holding Registers present in the module. For many registers the original copy exists in EEPROM. The address of this copy is given by the register number increased by 64. In the table below, for each address the EEPROM address is indicated if present. When the device is switched on (or at reset controlled by serial line) the RAM registers are initialised with the values contained in EEPROM. The EEPROM registers must therefore be programmed for configuration of the module. This configuration can be performed both with the module inserted in the bus together with other modules (obviously with a different address) or with module connected to the PC alone.

Address	INITIALS / Permitted values	Function
<b>40001</b>	<b>MTYPE, VERS</b>  0301	Contains the type (H) and number of the version (L) of the module. For the module Z-DAQ we can have: type=3, version=1. The value read is therefore worth 0x0301=769. It can be used to automatically recognise a module inserted in the bus to replace a faulty one and appropriately re-programme it. Note: the instrument version can vary from the value indicated above according to the revisions and/or updates carried out.
<b>40002</b> 40066	<b>CNFIN, TFILTRO</b> 1..13(H), 0..6(L)	Pre-sets the type of input (H) and the value of the filter time (L). See below for details.
<b>40003</b> 40067	<b>FSCAM</b> -32000..+32000	Measurement scale end: indicates the scale end in mV if the type of input is voltage, uA if the type of input is current, ohm if the type of input is resistance. It has no effect for the other types of input.
<b>40004</b> 40068	<b>ISCAM</b> -32000..+32000	Measurement scale beginning: as previously, referring to the beginning of the scale.
<b>40005</b> 40069	<b>FSCALA</b> -32000..+32000	Scale end in technical units: set automatically in the case of temperature measurements. Must be set as required for the other scales.
<b>40006</b> 40070	<b>ISCALA</b> -32000..+32000	Beginning of scale in technical units: as previously, referring to the beginning of the scale.
<b>40007</b> 40071	<b>STRIM</b> 9000..11000	Device span calibration. The rated value is 10000 and can be modified to adjust calibration of the measurement span.
<b>40008</b> 40072	<b>ZTRIM</b> -1000..+1000	Zero of the device. The rated value is 0 and can be modified to adjust calibration of the measurement zero.
<b>40009</b> 40073	<b>BAUDR</b> 0..4(H), 1..255(L)	Communication speed (H) and address (L) of the module. The speed can take the following values: 0=4800bps, 1=9600, 2=19200, 3=38400, 4=57600. The address can be between 1 and 255.
<b>40010</b> 40074	<b>EPRFLG</b>	Flags for setting various functions, see details further on.
<b>40011</b>	<b>VALUT</b>	Value measured in technical units.
<b>40012</b>	<b>VALLIN</b>	Value measured and scaled 0..10000.
<b>40013</b>	<b>STATUS</b>	Status/error flags, see details further on.

*Details of some registers:*

**CNFIN:** This register pre-sets the type of module input. After storing the required type in EEPROM, the module must be switched off and then on again, or re-set by means of the STATUS register RESET flag.

The configuration of the module for temperature measurement inputs (PT100, NI100, TC) also produces automatic programming of the FSCALA, ISCALA registers. In this way, temperature measurement will be available in the VALUT register expressed in tenths of a °C (1000 = 100.0 °C).

The following table gives the CNFIN value for each type of input and related measurement range.

CNFIN	Input type	Scale end
1	voltage input	0.05 ÷ 10V
2	input from potentiometer	0.35 ÷ 15kohm
3	current input	2.00 ÷ 20.00 mA
4	input from PT100	-200.0 ÷ 600.0 °C
5	input from NI100	-60 ÷ 180.0 °C
6	input from TC type J	-200.0 ÷ 1000.0 °C
7	input from TC type K	-250.0 ÷ 1200.0 °C
8	input from TC type R	0 ÷ 1750.0 °C
9	input from TC type S	0 ÷ 1750.0 °C
10	input from TC type T	-200.0 ÷ 400.0 °C
11	input from TC type B	0 ÷ 1800.0 °C
12	input from TC type E	-200.0 ÷ 800.0 °C
13	input from TC type N	-200.0 ÷ 1300.0 °C

For the other types of input, the scale in technical units is at the customer's discretion. In any case in the VALLIN register the measurement 0-10000 is available related to the scale ends set. E.g.: With CNFIN = 1, FSCAM = 200 (mV), ISCAM = -200 (mV), FSCALA = 20000, ISCALA = -20000, we can read the voltage value directly in uV in the VALUT register, while in the VALLIN register we will have a number ranging from 0 to 10000 when -200 mV and +200 mV are applied to the appropriate terminals.

**TFILTRO:** With this register it is possible to set a one-pole digital filter applied to the measurement. The values from 0 to 6 correspond to a filter of 0, 1, 2, 5, 10, 20, 60 seconds respectively.

**EPRFLG:** This register must be considered in binary format, i.e. each register bit activates (1) or de-activates (0) a function. The table shows the functions associated with each bit.

Bit:	Weight:	Function:
0	1	None
1	2	None
2	4	
3	8	
4	16	
5	32	None
6	64	None
7	128	None
8	256	=1: activates root extraction for the non-temperature type inputs.
9	512	Sets sensor breakage reaction (burn-out): 1= positive 0=negative.
10	1024	None
11	2048	None
12	4096	None
13	8192	None
14	16384	=1: sets four-wire reading for thermoresistance sensors (PT100, NI100).
15	32768	None

Register setting example: Bit 9=1, Bit 14=1, remaining = 0: the register value is given by the sum of the weights of each bit =1. In our case we have: 512+16384=16896.

**STATUS:** This register must be considered in binary format, i.e. each active bit (=1) of the register corresponds to an error or warning status. The table shows the functions associated with each bit.

Bit:	Weight:	Function:
0	1	This bit can be set to 1 to obtain <b>RESET</b> of the module. After the operation it will be automatically reset to 0.
1	2	Reserved, do not set to 1.
2	4	=1 a 12 ms delay is added to the serial MODBUS response. To be used when the device is connected to a radio modem or similar devices.
3	8	=0 no parity =1 parity (see following bit)
4	16	=0 odd parity =1 even parity
5	32	None
6	64	None
7	128	None
8	256	=1: data programming error. Active if the setting of the input type is not among those permitted.
9	512	=1: if the measurement is above FSCAM or FSCALA set +3% (overflow).
10	1024	=1: if the measurement is below ISCAM or ISCALA set -3% (underflow).
11	2048	=1: if sensor BURN-OUT has been detected.
12	4096	=1: EEPROM programming error. Active if the last programming of an EEPROM register has failed.
13	8192	=1: A/D converter failure.
14	16384	None
15	32768	None

## ***ERROR CODES***

In some situations the module may respond with an exception message. The following table lists these situations and the related response codes.

Situation	Response code
Illegal register address	02
Number of registers requested illegal	04
EEPROM register programming error	08

## ***MODULE PROGRAMMING EXAMPLES***

### **EXAMPLE no.1**

Function requested: Analogue input 1..5 V with scale 0..1000, without filter.  
Program the following registers with the values indicated:

**40066 = 256** (CNFIN = 1, TFIPTRO = 0, therefore:  $1 * 256 + 0$  ).  
**40067 = 5000** (FSCAM = 5000 mV)  
**40068 = 0** (ISCAM = 1000 mV)  
**40069 = 1000** (FSCALA = 1000)  
**40070 = 0** (ISCALA = 0)

Switch the instrument off and then on again or write 1 in the STATUS register.  
Subsequently the measurement will be available scaled 0..1000 in the register 40011 (VALUT).

### **EXAMPLE no.2**

Function requested: Thermocouple J input, with filter.  
Program the following registers with the values indicated:

**40066 = 1538** (CNFIN = 6, TFIPTRO = 2, therefore:  $6 * 256 + 2$  ).  
**40074 = 512** (Bit 9 = 1: BURN-OUT Positive, therefore: weight of bit 9 = 512)

Switch the instrument off and then on again or write 1 in the STATUS register.

Subsequently the measurement will be available in tenths of a °C in the register 40011 (VALUT). If the sensor fails, the status register contains the sensor failure information while the VALUT or VALLIN registers will be set beyond the maximum scale end.

### INDICATIONS ON FRONT FASCIA

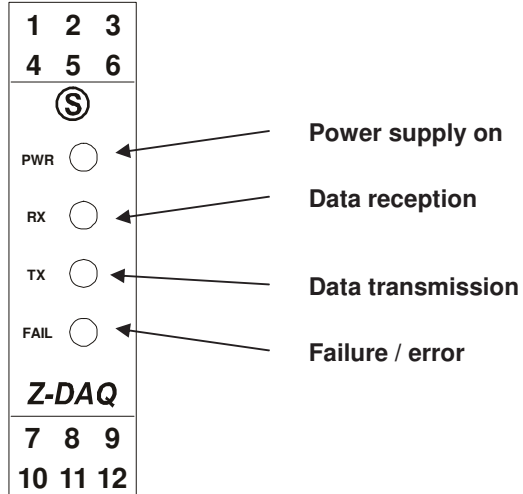

### OVERALL DIMENSIONS

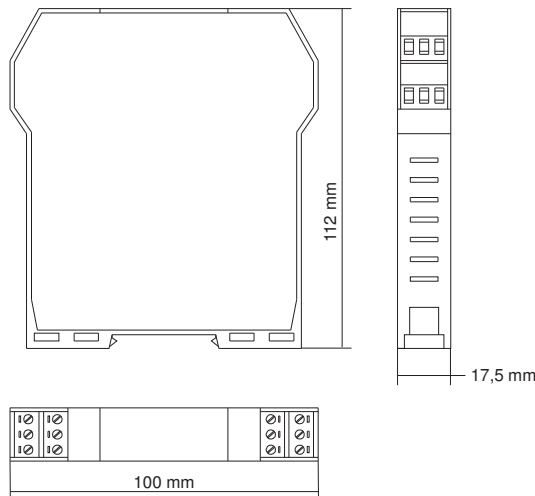

**AIRICOM**  
Groupe ZAR  
Ile de France  
Paris et Nord  
65 rue de la Libération - 60710 Chevières  
Tél 03.44.91.04.14 - Fax 03.44.91.04.15  
www.airicom.com - info@airicom.com

**AURECOM**  
Groupe ZAR  
Bretagne et  
Grand Ouest  
La Ville Cognac - 56430 Mauron  
Tél 02.97.22.79.72 - Fax 02.97.22.90.51  
www.aurecom.fr - info@aurecom.fr

**RG2i**  
Groupe ZAR  
Rhône Alpes  
Est et Sud-Est  
26 rue Bergson - 42000 Saint-Etienne  
Tél 04.77.92.03.56 - Fax 04.77.92.03.57  
www.rg2i.com - info@rg2i.fr

**ZAR** Groupe  
Votre contact